



**This meeting will be held in person
In Public Meeting Room A
Delta Administration Building
7710 West Saginaw Highway
Lansing, MI 48917**

**TOWNSHIP BOARD REGULAR MEETING
AGENDA
Monday, May 1, 2023 - 6:00 PM**

**This meeting will be streamed live for viewing only at:
<https://us02web.zoom.us/j/86223697147?pwd=eDlCYnNGTk9reTJHQU53RmIvcjMdz09>
Meeting ID: 862 2369 7147
Passcode: 754094**

**For the hearing impaired, please call 711 (TTY Support) to access the FCCs
phone relaying service and provide the following phone number 1-312-626-6799.
*Please note all public comments must be made in person.***

- I. CALL TO ORDER**
- II. OPENING CEREMONIES**
- III. ROLL CALL** – Members: Supervisor Kenneth R. Fletcher, Clerk Mary R. Clark, Treasurer Dennis R. Fedewa, Trustee Elizabeth (Beth) S. Bowen, Trustee Fonda J. Brewer, Trustee Andrea M. Cascarilla, and Trustee Karen J. Mojica
- IV. PRESENTATIONS AND PROCLAMATIONS**
 - 1. Delta Community Choir 10th Anniversary Resolution**
 - 2. Jasmine Star Miles Foundation Resolution of Tribute**
 - 3. Eaton County Drain Office Bank Intercounty Presentation**
- V. SET/ADJUST AGENDA**
- VI. PUBLIC HEARINGS** - Members of the public at the meeting shall not speak unless recognized by the chair. Members of the public shall be limited to speaking for a maximum of three (3) minutes during a public hearing. Prior to speaking, members of the public must also identify themselves with their name and address.
- VII. COMMUNICATIONS**
- VIII. PUBLIC COMMENTS (maximum three minutes)**
- IX. INTRODUCTION OF ORDINANCES**
- X. PASSAGE OF ORDINANCES**

XI. CONSENT AGENDA – Anyone may request item(s) to be pulled from the consent agenda for discussion. If left on the consent agenda, the items will be voted on by a roll call vote of the Board en masse. Then, the individual item(s) will be discussed and voted upon.

4. Bills and Financial Transactions

a. **\$ 3,250,836.23**

5. Minutes

a. **April 3, 2023**

b. **April 10, 2023**

6. WRRF Major Capital Improvements Phase 1 Approval of Change Order No 4

The Engineering Department recommends that the Delta Township Board approve the proposed Change Order No. 4 with Commercial Contracting Corporation, increasing the contract for Phase 1 of the Water Resource Recovery Facility Major Capital Improvements Project by \$36,914.78 for a total of \$73,306,501.

7. 2023 Concrete Sidewalk and Pathway Replacement Program Bid Results and Recommendation for Award

The Engineering Department recommends that the Delta Township Board accept the bid from Bearstone Construction for the 2023 Concrete Sidewalk and Pathway Replacement Program project in the amount of \$106,855.

8. 2023 Concrete Sidewalk and Pathway Raising Program Bid Results and Recommendation for Award

The Engineering Department recommends that the Delta Township Board accept the bid from A-1 Concrete Leveling and Foundation Repair for the 2023 Concrete Sidewalk and Pathway Raising Program project in the amount of \$21,926.

9. Referral of Rezoning Request for 5217 Old Lansing Rd in Case No. 03-23-07

The Planning Department Recommends that the Delta Township Board refer Jeremy Hill's request to rezone the property described in Case 03-23-07 from O-Office to RA-Very Low Density Residential, to the Planning Commission for the purposes of holding a public hearing on the matter and submitting a recommendation to the Township Board.

10. 2023 Municipal Water Well House Demolition Bid Results and Recommendation for Award

The Engineering Department recommends that the Delta Township Board accept the bid from Handy Excavating, LLC for the 2023 Municipal Water Well House Demolition project in the amount of \$46,000.00.

XII. ITEMS REMOVED FROM CONSENT AGENDA FOR DISCUSSION

XIII. ITEMS ADDED TO AGENDA UNDER SECTION V. SET/ADJUST AGENDA

XIV. OLD ITEMS OF BUSINESS

XV. NEW ITEMS OF BUSINESS

11. Waverly Community Schools Pool Lease Extension Agreement

The Parks Recreation and Cemeteries Department recommends that the Delta Township Board approve the Addendum to the Swimming Pool Agreement with the Waverly Community School District.

12. **2023 Administration Building Interior Modifications Bid Results and Recommendation for Award**
The Engineering Department recommends that the Delta Township Board accept the bid from Wolverine Building Group for the 2023 Administration Building Interior Modifications project in the amount of \$176,359.00.

XVI. MANAGER'S REPORT

XVII. COMMITTEE OF THE WHOLE

13. **Private Development Update**
14. **Fire Department Annual Report**

XVIII. CLOSED SESSION

XIX. PUBLIC COMMENTS (maximum three minutes)

XX. ADJOURNMENT

CHARTER TOWNSHIP OF DELTA

MARY R. CLARK, TOWNSHIP CLERK
Phone (517) 323-8500

Individuals with disabilities attending Township meetings or hearings and requiring auxiliary aids or services should contact Township Manager and ADA Coordinator Brian T. Reed by email at manager@deltami.gov or calling (517) 323-8590 to inform him of the date of the meeting or hearing that will be attended. Copies of minutes may be purchased or viewed in the Clerk's Office from 8 a.m. to 5 p.m., Monday through Friday.



**CHARTER TOWNSHIP OF DELTA
RESOLUTION OF RECOGNITION OF
10TH ANNIVERSARY OF THE DELTA COMMUNITY CHOIR**

WHEREAS, The Delta Community Choir is celebrating their 10th Anniversary; and

WHEREAS, the organization is a not-for-profit adult Soprano, Alto, Tenor, Bass (SATB) choir that combines the love of choral singing with community service; and

WHEREAS, the Delta Community Choir was created to build community through song by providing individuals with a forum for music education and self-expression through the choral arts; and

WHEREAS, The Delta Community Choir is Directed by the talented Ellen McKenzie, whose passion has helped to inspire over 60 diverse individuals to comingle their talents to create beautiful music for the sole purpose of giving back to their community; and

WHEREAS, The choir performs two concerts each year (spring and winter) and charges no admission but rather, each concert spotlights a local non-profit organization that benefits from freewill donations from audience members; and

WHEREAS, Through its performances, the Delta Community Choir has generated more than \$36,000, with 100% of those dollars going to support local non-profit organizations, many supporting or located in the Delta Township Community.

NOW THEREFORE, BE IT HEREBY RESOLVED that on this first day of May two-thousand twenty-three the Delta Township Board does hereby recognize and celebrate the 10th Anniversary of the Delta Community Choir and thank them for their contributions and support of the Delta Township Community.

Kenneth R. Fletcher, Supervisor

Mary R. Clark, Clerk

Dennis R. Fedewa, Treasurer

Elizabeth S. Bowen, Trustee

Fonda J. Brewer, Trustee

Andrea M. Cascarilla, Trustee

Karen J. Mojica, Trustee





**CHARTER TOWNSHIP OF DELTA
RESOLUTION OF TRIBUTE RECOGNIZING
THE JASMINE STAR MILES FOUNDATION**

WHEREAS, the Jasmine Star Miles Memorial Foundation was established in 2005 to honor 13-year-old Waverly Middle School Student, Jasmine Star Miles who tragically lost her life in a pedestrian- automobile accident while walking home from school; and

WHEREAS, to ensure Jasmine’s giving nature lived on, the Jasmine Star Miles Memorial Foundation was founded by Jasmine’s family and friends with the goal to improve pedestrian safety and serve the community that Jasmine loved; and

WHEREAS, the Foundation established the Jasmine Star Miles Memorial Scholarship Fund to reflect the vibrant light and love of Jasmine to deserving college-bound high school seniors in the Lansing Area. Since its inception, the Jasmine Star Miles Foundation has awarded over 20 Scholarships; and

WHEREAS, on May 13, 2023 the Jasmine Star Miles Scholarship Tea, “Butterflies in Paradise” will celebrate the 20th Anniversary of Jasmine’s homegoing by reflecting on her community impact over the years and awarding three scholarships, the Waverly Warrior Award, the Les Meres et Debutantes of Greater Lansing Community Service Award, and the Greater Lansing Area School District: Butterfly Award

NOW THEREFORE, BE IT HEREBY RESOLVED that on this first day of May two-thousand twenty-three the Delta Township Board does hereby recognize the Jasmine Star Miles Memorial Foundation and its commitment to honoring the life and legacy of Jasmine Star Miles and its service to the community.

Kenneth R. Fletcher, Supervisor

Mary R. Clark, Clerk

Dennis R. Fedewa, Treasurer

Elizabeth S. Bowen, Trustee

Fonda J. Brewer, Trustee

Andrea M. Cascarilla, Trustee

Karen J. Mojica, Trustee



**DELTA CHARTER TOWNSHIP
FINANCE REPORT
FOR TOWNSHIP BOARD MEETING
5/1/2023**

Disbursement requests listed on the following pages, totaling \$3,250,836.23 have been received and reviewed by the Manager, Finance Director, and Clerk. It is recommended that all listed vouchers be approved for payment.

Payroll & Related	424,732.61
Refunds	2,452.14
Tax Distributions	-
Vendor Claims	<u>2,823,651.48</u>
Total	<u><u>\$ 3,250,836.23</u></u>

Kenneth R. Fletcher, Township Supervisor

Mary R. Clark, Township Clerk

Dennis R. Fedewa, Township Treasurer

**PAYABLES FOR DELTA CHARTER TOWNSHIP
BOARD AGENDA DATE
5/1/2023**

Check Date	Check	Invoice Vendor	Description	Amount
04/12/2023	326827	IEVA INGLIS	REFUND PAYMENT	167.33
04/12/2023	326828	AMBS MESSAGE CENTER	ANSWERING SERVICE - UTILITIES (4/1/2023-	162.00
04/12/2023	326829	APPLIED INNOVATION	REPAIR TO FOLDING MACHINE	370.00
04/12/2023	326830	AUTO VALUE PARTS STORE	MISC PARTS & SUPPLIES	1,593.94
04/12/2023	326832	BLACKBURN MANUFACTURING CO.	MISS DIG PAINT & FLAGS	1,133.00
04/12/2023	326833	BOUND TREE MEDICAL, LLC	MEDICAL SUPPLIES	3,042.58
04/12/2023	326834	CAPITAL ASPHALT LLC	COLD PATCH	1,745.70
04/12/2023	326835	CINTAS CORPORATION #725	MATS FOR SUBSTATION	40.18
04/12/2023	326836	COMCAST	COMCAST SERVICE FOR 7708 ADMINISTRATION	42.35
04/12/2023	326837	CONSUMERS ENERGY	SERVICE @ MULTIPLE LOCATIONS, STREETLIGHTS	3,877.87
04/12/2023	326838	CRIPPEN	VEHICLE REPAIRS	485.04
04/12/2023	326839	DARLING INGREDIENTS, INC.	OUTDOOR GREASE COLLECTION	75.00
04/12/2023	326840	DBI BUSINESS INTERIORS	OFFICE & OPERATING SUPPLIES	2,222.38
04/12/2023	326841	DETECTION INSTRUMENTS CORP.	CALIBRATION FOR H2'S	222.41
04/12/2023	326842	EATON COUNTY TREASURER	2022 FORD F150 WEIGHMASTER VEHICLE	40,845.00
04/12/2023	326843	ETNA SUPPLY COMPANY	CURB STOPS, MXU, HANDLES FOR SERVICE VALVES	2,146.18
04/12/2023	326844	FACILITY SOLUTIONS, INC.	CLEANING SUPPLIES	2,441.09
04/12/2023	326845	FERGUSON WATERWORKS #3386	CURB BOX/STOP REPLACEMENT PARTS	1,789.59
04/12/2023	326846	FIBERTEC ENVIRONMENTAL SERVICES	BIOSOLIDS - PFAS IPP, & HG MONITORING	1,039.00
04/12/2023	326847	FLEETPRIDE	WASHERS & LOCK RINGS	11.97
04/12/2023	326848	FLUID CONNECTIONS, INC	PARTS FOR SHOP HOSE	225.94
04/12/2023	326849	GRAINGER	JANITORIAL SUPPLIES	320.52
04/12/2023	326850	HAMMOND FARMS	SOIL	121.88
04/12/2023	326851	HOFFMAN PHOTOGRAPHY	MOTHER DAUGHTER DANCE PHOTOGRAPHY	747.00
04/12/2023	326852	KENDALL ELECTRIC INC.	EL2 PARTS - ULTIUM LIFT STATION PANEL	843.79
04/12/2023	326853	LANSING BOARD OF WATER & LIGHT	LAB FEES & WHOLESALE WATER - MARCH 2023	217,224.58
04/12/2023	326854	CROWNE PLAZA LANSING WEST	MOTHER DAUGHTER DANCE	1,452.00
04/12/2023	326855	LOOMIS	ARMORED SERVICE - MARCH 2023	387.00
04/12/2023	326856	LYDEN OIL COMPANY	GREASE	579.60
04/12/2023	326857	MAURER'S	UTILITIES UNIFORMS - MARCH 2023	733.56

04/12/2023	326858	MENARDS	MISC PARTS, TOOLS & SUPPLIES	559.77
04/12/2023	326859	METTLER-TOLEDO, INC.	BASIC TEST REPORT - MICHAEL STAFFORD	280.74
04/12/2023	326860	KYLA MOORE	REFUND FOR NOTARY FEES	32.67
04/12/2023	326861	PINNACLE RECOVERY GROUP	PERSONAL PROPERTY TAX OVERPAYMENT REFUND	3.85
04/12/2023	326862	MUNICIPAL SUPPLY CO.	REPAIR CLAMP & EL2 PARTS	1,235.27
04/12/2023	326863	NCL OF WISCONSIN	LAB CHEMICALS	89.31
04/12/2023	326864	NELSON TANK ENGINEERING & CONS	PAINT INSPECTION SERVICES FOR MILLETT TANK	1,300.00
04/12/2023	326865	KRISTINE SIGURANI	REFUND P&R RENTAL DEPOSIT	545.00
04/12/2023	326866	PROCESS ENGINEERING & EQUIPMENT CO.	PARTS FOR LIME PUMPS	3,812.64
04/12/2023	326867	PVS TECHNOLOGIES, INC.	FERRIC CHLORIDE SOLUTION	20,809.16
04/12/2023	326868	QUALITY TIRE, INC.	TIRES & BALANCING	594.68
04/12/2023	326869	SUNDANCE CHEVROLET	TRANSMISSION MOUNT	75.14
04/12/2023	326870	USA BLUE BOOK	BRASS PLUG	66.59
04/12/2023	326871	IEVA INGLIS	REFUND PAYMENT	167.33
04/12/2023	326872	AMBS MESSAGE CENTER	ANSWERING SERVICE - UTILITIES (APR 23)	162.00
04/12/2023	326873	APPLIED INNOVATION	REPAIR TO FOLDING MACHINE	370.00
04/12/2023	326874	AUTO VALUE PARTS STORE	MISC PARTS & SUPPLIES	1,593.94
04/12/2023	326876	BLACKBURN MANUFACTURING CO.	MISS DIG PAINT & FLAGS	1,133.00
04/12/2023	326877	BOUND TREE MEDICAL, LLC	MEDICAL SUPPLIES	3,042.58
04/12/2023	326878	CAPITAL ASPHALT LLC	COLD PATCH	1,745.70
04/12/2023	326879	CINTAS CORPORATION #725	MATS FOR SUBSTATION	40.18
04/12/2023	326880	COMCAST	COMCAST SERVICE FOR 7708 ADMINISTRATION	42.35
04/12/2023	326881	CONSUMERS ENERGY	SERVICE @ MULTIPLE LOCATIONS, STREETLIGHTS	3,877.87
04/12/2023	326882	CRIPPEN	VEHICLE REPAIRS	485.04
04/12/2023	326883	DARLING INGREDIENTS, INC.	OUTDOOR GREASE COLLECTION	75.00
04/12/2023	326884	DBI BUSINESS INTERIORS	OFFICE & OPERATING SUPPLIES	2,222.38
04/12/2023	EFT	CSC	RECORDING FEE - ST JOE WATER MAIN PATHWAY	117.00
04/13/2023	EFT	CSC	RECORDING FEE - ST JOE WATER MAIN PATHWAY	78.00
04/19/2023	326892	ALLEGRA PRINT & IMAGING	DELTA NOW! MAGAZINE	3,542.09
04/19/2023	326893	BLUE CROSS BLUE SHIELD OF MICHIGAN	HEALTH INSURANCE MAY 2023	162,369.61
04/19/2023	326894	BRD PRINTING, INC.	BUSINESS CARDS - MOLINE & MENSER	73.60
04/19/2023	326895	CANON FINANCIAL SERVICES, INC.	MONTHLY COPIER CONTRACT CHARGE - APRIL 2023	1,307.17
04/19/2023	326896	MILLS FUNERAL HOME	REFUND - CEMETERY DEPOSIT	300.00
04/19/2023	326897	DEARMAN, ROBERT	REFUND - CEMETERY DEPOSIT	200.00
04/19/2023	326898	CONSUMERS ENERGY	SERVICE @ MULTIPLE LOCATIONS (MAR - APR 23)	3,281.92

04/19/2023	326899	DEARBORN NATIONAL LIFE INSURANCE CO	LIFE, ADD, LTD & OPT'L INSURANCE - MAY 2023	7,817.42
04/19/2023	326900	DELTA DENTAL PLAN OF MICHIGAN	DENTAL INSURANCE - MAY 2023	15,423.52
04/19/2023	326901	DICKINSON WRIGHT PLLC	SANITARY INTERCEPTOR & CIA PROF SERVICES	1,248.20
04/19/2023	326902	DUNIGAN BROTHERS	ULTIUM CELLS BID PACK 1 PAYMENT 4	1,573,578.64
04/19/2023	326903	JOHN DEERE FINANCIAL	SUPPLIES & MATERIALS FOR MULT DPTS - APR 23	2,625.01
04/19/2023	326904	FENEIS, DONALD	PURCHASING CEMETERY PLOTS BACK	780.00
04/19/2023	326905	USA TODAY NETWORK	NOTARIZED ADVERTISING - JAN & FEB 2023	816.85
04/19/2023	326906	GONZALES, MARY	OPTION AGREEMENT FOR ST JOE WATER MAIN	500.00
04/19/2023	326907	GRANGER	CONTAINER SERVICE @ MULTIPLE LOCATIONS - APR 23	1,740.31
04/19/2023	326908	HAMMOND FARMS	SOIL	75.00
04/19/2023	326909	DBA THE PARK CATALOG	GALVANIZED METAL FRAME PICNIC TABLE	4,068.00
04/19/2023	326910	KELBY LEIBY	REIMBURSEMENT - FOOD FOR LIVE FIRE TRAIN	149.75
04/19/2023	326911	LOWES BUSINESS ACCOUNT	SUPPLIES & MATERIALS FOR MULTIPLE DEPTS	2,786.36
04/19/2023	326912	MENARDS	MISC PARTS & SUPPLIES	122.73
04/19/2023	326913	MICH CONF ASSOC OF SEVENTH DAY ADV	OPTION AGREEMENT FOR ST JOE WATER MAIN	500.00
04/19/2023	326914	SAMI, ADAM MASUD	REFUND BD PAYMENT	22.50
04/19/2023	326915	CANON SOLUTIONS AMERICA, INC.	COPIER MAINTENANCE - APR 23	63.50
04/19/2023	326916	SPICER GROUP	CARRIER CREEK PROF SERVICES THROUGH 02/28/23	16,120.25
04/19/2023	326917	WEST ST. JOSEPH PROPERTY, LLC	OPTION AGREEMENT FOR ST JOE WATER MAIN	200.00
04/19/2023	326918	STUDENT STATESMANSHIP INSTITUTE	OPTION AGREEMENT FOR ST JOE WATER MAIN	500.00
04/19/2023	326919	THRUN LAW FIRM P.C.	LEGAL SERVICES - MARCH 2023	1,390.00
04/19/2023	326920	UTRUP, ROBERT & MICHELLE	PURCHASING CEMETERY PLOTS BACK	780.00
04/19/2023	326921	VOYANT COMMUNICATIONS	PHONE & INTERNET SERVICE APR 2023	4,018.85
04/26/2023	326931	AT&T	PHONE SERVICE @ RECYCLING CENTER (MAR - APR 23)	126.44
04/26/2023	326932	BRD PRINTING, INC.	PUBLIC SAFETY MILLAGE POSTCARDS & BUSINESS CARDS	1,702.49
04/26/2023	326933	CAPITAL AREA UNITED WAY	PAYROLL WITHHOLDING 04/07/23	29.23
04/26/2023	326934	CAPITAL AREA UNITED WAY	PAYROLL WITHHOLDING 04/21/23	29.23
04/26/2023	326935	CONNIE WEEMS	REFUND - CEMETERY DEPOSIT	300.00
04/26/2023	326936	CONSUMERS ENERGY	SERVICE @ MULTIPLE LOCATIONS (MAR - APR 23)	4,499.42
04/26/2023	326937	D & K TRUCK COMPANY	SUTPHEN MONARCH ALIGNMENT	92.46
04/26/2023	326938	ETNA SUPPLY COMPANY	3/4" GASKETS FOR COMP FITTINGS	230.00
04/26/2023	326939	FLEETPRIDE	KING PIN KIT & CLAMP	554.27
04/26/2023	326940	FRATE PRODUCTIONS	MUSIC IN THE PARK	1,200.00
04/26/2023	326941	FRIEDLAND INDUSTRIES	CONFIDENTIAL SHREDDING	50.00
04/26/2023	326942	HML	SLUDGE PATHOGEN REDUCTION SA#442693	1,100.00

04/26/2023	326943	KIMBALL MIDWEST	MISC PARTS	945.20
04/26/2023	326944	LANSING BOARD OF WATER & LIGHT	SERVICE @ MULTIPLE LOCATIONS (MAR - APR 23)	2,935.84
04/26/2023	326945	EDWARD JULIUS-ROY ALEXANDER	REFUND P&R RENTAL DEPOSIT - CANCELLED RENTAL	275.00
04/26/2023	326946	LEE PHELPS	UMPIRE FEE REIMBURSEMENT	165.00
04/26/2023	326947	STARR ALLEN	REFUND P&R RENTAL DEPOSIT	250.00
04/26/2023	326948	REVELS TURF & TRACTOR	TURFTIME AR1007	400.00
04/26/2023	326949	R.M. ELECTRIC, INC.	REPAIR OF LIGHT @ SENIOR CENTER	1,146.05
04/26/2023	326950	SAFETY-KLEEN SYSTEMS, INC.	RECYCLING - OIL	54.40
04/26/2023	326951	SAFEWARE, INC.	GAS MONITORS	2,527.72
04/26/2023	326952	KATHY SOBCZYK	REIMBURSEMENT FOR STAKES FOR POP-UP GOAL	60.18
04/26/2023	326953	LO, YEE	REFUND W/S FOR ACCOUNT: 00020796	134.77
04/26/2023	326954	TRANSNATION TITLE AGENCY	REFUND W/S FOR ACCOUNT: 00028560	22.42
04/26/2023	326955	SASS, QUINTON	REFUND W/S FOR ACCOUNT: 00035153	21.71
04/26/2023	326956	HAGERTY, JOHN	REFUND W/S FOR ACCOUNT: 00015258	13.41
04/26/2023	326957	XYLEM WATER SOLUTIONS USA, INC.	UV LAMPS	6,150.00
05/03/2023	326958	A&L GREAT LAKES LABORATORIES	SOIL TESTING FOR BIOSOLIDS	58.50
05/03/2023	326959	AC&E RENTALS	EQUIP RENTAL FOR CONCRETE REMOVAL	78.10
05/03/2023	326960	ACE HARDWARE OF GRAND LEDGE	MISC SUPPLIES	63.97
05/03/2023	326961	ADVANCED TURF SOLUTIONS, INC.	IMPACT RP, GROUND SUPPLIES	7,219.15
05/03/2023	326962	AIRGAS USA, LLC	OXYGEN	375.43
05/03/2023	326963	AMERICAN RENTALS, INC.	PORTABLE TOILETS	776.00
05/03/2023	326964	APOLLO FIRE APPARATUS	STAINLESS STEEL BUCKLES	164.50
05/03/2023	326965	AUTO VALUE PARTS STORE	MISC PARTS & SUPPLIES	975.51
05/03/2023	326966	BATCO, INC.	JACOB STANLEY - MAY 9, KALAMAZOO	150.00
05/03/2023	326967	BLUESTONE PSYCH	NEW FF EMT-B PSYCH EVAL	465.00
05/03/2023	326968	BOUND TREE MEDICAL, LLC	MEDICAL SUPPLIES	30.99
05/03/2023	326969	BRD PRINTING, INC.	PUBLIC SAFETY MILLAGE POSTCARD - POSTAGE	480.09
05/03/2023	326970	BS&A SOFTWARE	BSA APPLICATION SOFTWARE - HR, TAX, EMPLOYEE, ETC	12,451.00
05/03/2023	326971	CDW GOVERNMENT, INC.	MOBILE DEVICE MGMT 3 YR LICENSE & CURVED MONITOR	1,167.19
05/03/2023	326972	CINTAS CORPORATION #725	MATS FOR SUBSTATION	80.36
05/03/2023	326973	CITY OF LANSING	GM SANITARY SEWER 425 AGREEMENT (02/23 - 03/17)	45,164.46
05/03/2023	326974	COMMERCIAL BLUEPRINT, INC.	2023 TAX BASE MAPS	318.66
05/03/2023	326975	DINGES FIRE COMPANY	SMOKE LIQUID	669.76
05/03/2023	326976	EATON COUNTY	1ST QUARTER 2023 CROSSING GUARDS	2,844.31
05/03/2023	326977	EATON COUNTY TREASURER	SHERIFF CONTRACTUAL - MAY 2023	337,843.00

05/03/2023	326978	EATON COUNTY TREASURER	2023 PRE CHANGES	45.06
05/03/2023	326979	EATON COUNTY ROAD COMMISSION	SIGNAL ENERGY JANUARY 2023	23.98
05/03/2023	326980	J.C. EHRLICH	PEST CONTROL MAINTENANCE	70.00
05/03/2023	326981	ETNA SUPPLY COMPANY	VACUUM BREAKER REPAIR PARTS, COUPLINGS	502.40
05/03/2023	326982	FACILITY SOLUTIONS, INC.	SANITARY SUPPLIES	152.66
05/03/2023	326983	FERGUSON WATERWORKS #3386	VALVE & GASKETS, PIPE, COUPLERS	940.52
05/03/2023	326984	FIBERTEC ENVIRONMENTAL SERVICES	IPP & HG MONITORING	270.00
05/03/2023	326985	FISH WINDOW CLEANING	WINDOW CLEANING @ TOWNSHIP OFFICES	745.00
05/03/2023	326986	FLUID CONNECTIONS, INC	PARTS FOR HYDRANT PAINTING	167.15
05/03/2023	326987	FORESIGHT SUPER SIGN	DIE CUT RECTANGLES	450.00
05/03/2023	326988	GALLS, LLC	CARBON TAC TOE BOOT	568.65
05/03/2023	326989	GRAINGER	VOLLEY BALL NETS & UTILITY CONTAINERS	1,618.59
05/03/2023	326990	GRE-CAR TRUCKING, INC.	HARDWOOD	4,200.00
05/03/2023	326991	HAMMOND FARMS	SOIL	1,130.25
05/03/2023	326992	HAWORTH, INC	REPLACEMENT DESK PARTS	895.35
05/03/2023	326993	KIMBALL MIDWEST	MISC PARTS & SUPPLIES	1,417.94
05/03/2023	326994	KODIAK EMERGENCY VEHICLES	EXTERIOR LOCKING HANDLES	549.66
05/03/2023	326995	LACROSSE SEED	TURF FOOD & WINTERIZER	447.30
05/03/2023	326996	LAFONTAINE FORD, INC.	TIE ROD & SPINDLE	341.96
05/03/2023	326997	AUGUSTINE MARTINEZ	MUSIC IN THE PARK	300.00
05/03/2023	326998	MENARDS	TOOLS FOR MOWER BLADE SHARPENER	83.30
05/03/2023	326999	MICHIGAN ASSOCIATION OF PLANNING	MEMBERSHIP - P.MENSER	65.00
05/03/2023	327000	MICHIGAN COMPANY, INC.	JANITORIAL SUPPLIES	600.64
05/03/2023	327001	MID-STATES BOLT & SCREW CO.	NUTS & BOLTS FOR METER SETS	288.79
05/03/2023	327002	MICHIGAN RURAL WATER ASSO.	BRAD MEISTER - EXCAVATION & TRENCH	290.00
05/03/2023	327003	MOORE & BRUGGINK, INC.	DELTA MILLS PARK TOPOGRAPHIC SURVEY	10,835.00
05/03/2023	327004	MOTION INDUSTRIES, INC.	BELT FOR LIFT STATION	383.50
05/03/2023	327005	MICHIGAN WATER ENVIRONMENT ASSOC.	DAVID D'HAENE - 5/17/23 PROCESS & SUSTAINABILITY	170.00
05/03/2023	327006	MYERS PLUMBING & HEATING, INC.	BOILER REPAIR & DRAIN CLEANING	937.13
05/03/2023	327007	NCL OF WISCONSIN	LAB CHEMICALS	2,544.50
05/03/2023	327008	NORTH GRAND RIVER COOPERATIVE	DELTA FIRE MEDICAL LINENS	542.49
05/03/2023	327009	NYE UNIFORM	UNIFORMS	2,184.38
05/03/2023	327010	OHM ADVISORS	WILLOW LS, GM ULTIUM, FORCEMAIN PROF SERVICES	105,106.85
05/03/2023	327011	PROVIDENCE CONSULTING COMPANY	MICROSOFT 365	2,074.30
05/03/2023	327012	PVS TECHNOLOGIES, INC.	FERRIC CHLORIDE SOLUTION	10,299.03

05/03/2023	327013	RAPIDS'S AUTO SERVICE	ALIGNMENT	85.00
05/03/2023	327014	R.M. ELECTRIC, INC.	REPAIRING ELECTRIC @ ADMIN BUILDING	987.73
05/03/2023	327015	ROSE PEST SOLUTIONS	MONTHLY PEST CONTROL	57.00
05/03/2023	327016	SAFEWARE, INC.	MULTIRAE GAS DETECTOR	7,204.78
05/03/2023	327017	SCHINDLER ELEVATOR CORP.	WATER DAMAGE	1,982.29
05/03/2023	327018	SCHULTZ, INC	EMERGENCY MOBILIZATION SERVICE - POWER WASH	2,000.00
05/03/2023	327019	SWAGG PROMOTIONS, LLC	MUSIC IN THE PARK PERFORMANCE - MAY 16	200.00
05/03/2023	327020	TETRA TECH, INC.	WWTP IMPVMTS, CARRIER CREEK PROF SERVICES	82,344.51
05/03/2023	327021	ULINE, INC	TRASH PICKERS & CLEAR POLYSHEETING	1,198.02
05/03/2023	327022	WALLACE OPTICIANS	SAFETY GLASS - MIKE JOHNS	323.20
05/03/2023	327023	WATKINS ROSS & CO.	RETIREE HEALTH CARE PLAN REPORTING	5,100.00
				<hr/>
			PAYABLES	\$ 2,826,162.08
			PAYROLL PAY ENDING 04/15/2023	\$ 424,674.15
				<hr/>
				<u>\$ 3,250,836.23</u>

CHARTER TOWNSHIP OF DELTA
Public Meeting Room A
Delta Township Administration Building
7710 West Saginaw Highway
Lansing, MI 48917

**TOWNSHIP BOARD REGULAR MEETING MINUTES FOR
MONDAY, APRIL 3, 2023**

I. CALL TO ORDER

Supervisor Fletcher called the meeting to order at 6:00pm.

II. OPENING CEREMONIES – Pledge of Allegiance

III. ROLL CALL

Members Present: Supervisor Kenneth R. Fletcher, Clerk Mary R. Clark, Treasurer Dennis R. Fedewa, Trustee Elizabeth S. Bowen, Trustee Fonda J. Brewer, and Trustee Karen J. Mojica

Members Absent: Trustee Andrea M. Cascarilla

Others Present: Manager Brian T. Reed, Finance Director Courtney Nicholls, Building Director Matt Leach, Deputy Clerk Shea Mattson, Township Engineer Ernie West, Lieutenant Elbert (Al) Sidel, Human Resource Director Kyla Moore, Parks, Recreation and Cemeteries Director Marcus Kirkpatrick, Planning Director Gary Bozek, Planner Matthew McKernan, Community & Economic Development Director Peter Menser, Utilities Director Rick Kane.

TRUSTEE BOWEN MOVED TO EXCUSE TRUSTEE MOJICA FROM THE APRIL 3, 2023, REGULAR BOARD MEETING.

TRUSTEE MOJICA SUPPORTED THE MOTION. THE MOTION PASSED 6-0.

IV. PRESENTATIONS AND PROCLAMATIONS

1. CATA Presentation

Brad Funkhouser, CATA CEO/Executive Director, Andrew Brieschke, CATA Deputy CEO, and Dustin Hagfors, CATA Director of Planning and Development gave a presentation on the implementation of a route 3 extension to Marketplace Drive.

MONDAY, APRIL 3, 2023, TOWNSHIP BOARD MINUTES – REGULAR MEETING
CHARTER TOWNSHIP OF DELTA

V. SET/ADJUST AGENDA

TRUSTEE BREWER MOVED TO APPROVE THE AGENDA AS AMENDED.

TRUSTEE MOJICA SUPPORTED THE MOTION. THE MOTION PASSED 6-0.

VI. PUBLIC HEARING

2. St. Gerard Church Noise Waiver

TRUSTEE MOJICA MOVED THAT THE DELTA TOWNSHIP BOARD APPROVE THE REQUEST BY ST. GERARD CHURCH FOR A WAIVER OF THE NOISE ORDINANCE BETWEEN THE HOURS OF 12:00 P.M. AND 11:30 P.M. ON MAY 6, 2023 FOR THE PURPOSE OF HOLDING THEIR ANNUAL CHURCH FESTIVAL.

CLERK CLARK SUPPORTED THE MOTION. THE MOTION PASSED 6-0.

VII. COMMUNICATIONS

VIII. PUBLIC COMMENTS

Tricia Schneeberger, 11351 Broadbent Rd. – Spoke regarding the notification about the Broadbent development.

IX. INTRODUCTION OF ORDINANCES

X. PASSAGE OF ORDINANCES

XI. CONSENT AGENDA

TRUSTEE BREWER MOVED TO APPROVE THE CONSENT AGENDA AS PRESENTED.

TRUSTEE MOJICA SUPPORTED THE MOTION.

ROLL CALL:

AYES: SUPERVISOR FLETCHER, CLERK CLARK, TREASURER FEDEWA, TRUSTEE BOWEN, TRUSTEE BREWER, AND TRUSTEE MOJICA

NAYS: NONE

ABSENT: TRUSTEE CASCARILLA

THE MOTION PASSED 6-0.

3. Bills and Financial Transactions

Bonds/Debt Payments	\$	
Payroll & Related	\$	409,618.63
Refunds	\$	4,249.03
Tax Distributions	\$	
Vendor Claims	\$	839,307.03
Total	\$	1,253,174.69

TRUSTEE
BREWER

MOVED TO APPROVE THE CONSENT AGENDA AS PRESENTED.

TRUSTEE MOJICA SUPPORTED THE MOTION. THE MOTION PASSED
6-0.

4. Minutes

a. Monday, Monday March 20, 2023

TRUSTEE BREWER MOVED TO APPROVE THE CONSENT AGENDA
AS PRESENTED.

TRUSTEE MOJICA SUPPORTED THE MOTION. THE MOTION PASSED
6-0.

5. Vehicle Order Request

TRUSTEE BREWER MOVED THAT THE DELTA TOWNSHIP BOARD
APPROVE THE ORDER REQUEST FOR TWO PICKUP TRUCKS FOR THE
UTILITY DEPARTMENT, ONE PICKUP TRUCK FOR THE BUILDING
DEPARTMENT, AND TWO TRUCKS FOR THE PARKS DEPARTMENT.

TRUSTEE MOJICA SUPPORTED THE MOTION. THE MOTION PASSED 6-
0.

**6. Introduction of Broadbent Development, LLC Rezoning Request, AG2 to
RC, Southwest Corner of Broadbent/M-43 in Case 1-23-5**

TRUSTEE BREWER MOVED THAT THE DELTA TOWNSHIP BOARD
INTRODUCE THE REZONING REQUEST DESCRIBED IN CASE NO. 1- 23-5
TO REZONE SUBJECT PROPERTY FROM AG2,
AGRICULTURAL/RESIDENTIAL, TO RC, MODERATE DENSITY
RESIDENTIAL. I FURTHER MOVE THAT REZONING REQUEST BE
CONSIDERED FOR FINAL ACTION BY THE TOWNSHIP BOARD AT THE
NEXT SUBSEQUENT REGULAR BOARD MEETING. THE CLERK IS
HEREBY DIRECTED TO PUBLISH NOTICE OF SAID MEETING IN THE
LOCAL NEWSPAPER, AS IS REQUIRED.

TRUSTEE MOJICA SUPPORTED THE MOTION. THE MOTION PASSED 6-0.

7. Ultium 3 Battery Plant Water and Sanitary Sewer Service Approval of Change Items

Action #1 – Acceptance of Change Orders from Dunigan Brothers

TRUSTEE BREWER MOVED THAT THE DELTA TOWNSHIP BOARD APPROVE THE PROPOSED CHANGE ORDERS WITH DUNIGAN BROTHERS FOR THE ULTIUM 3 BATTERY PLANT WATER AND SANITARY SEWER SERVICE PROJECTS, INCREASING THE CONTRACT PRICES FOR BID PACKAGE #1 BY \$48,358.72 AND FOR BID PACKAGE #2 BY \$152,647.00.

I FURTHER MOVE THAT THE TOWNSHIP MANAGER BE AUTHORIZED AND DIRECTED TO EXECUTE THE CHANGE ORDERS ON BEHALF OF THE TOWNSHIP.

TRUSTEE MOJICA SUPPORTED THE MOTION. THE MOTION PASSED 6-0.

Action #2 – Acceptance of Engineering Contract Amendments from OHM Advisors

TRUSTEE BREWER MOVED THAT THE DELTA TOWNSHIP BOARD ACCEPT THE PROPOSED CONTRACT AMENDMENT NO. 5 WITH OHM FOR THE ULTIUM 3 BATTERY PLANT WATER AND SANITARY SEWER SERVICE PROJECT, FOR THE PURPOSE OF PROVIDING ADDITIONAL ENGINEERING SERVICES TO INCREASE THE DESIGN CAPACITY OF THE ULTIUM 3 LIFT STATION IN THE AMOUNT OF \$48,788.

I FURTHER MOVE THAT THE TOWNSHIP MANAGER BE AUTHORIZED AND DIRECTED TO EXECUTE AN AGREEMENT FOR SAID SERVICES ON BEHALF OF DELTA TOWNSHIP.

TRUSTEE MOJICA SUPPORTED THE MOTION. THE MOTION PASSED 6-0.

8. Fireworks Permit & Agreement

TRUSTEE BREWER MOVED THAT THE DELTA TOWNSHIP BOARD APPROVE THE REQUEST BY PARKS, RECREATION AND CEMETERIES COMMISSION BE GRANTED FOR A FIREWORKS DISPLAY ON JULY 3, 2023, IN THE AMOUNT OF \$34,650, WITH AN AGREED UPON RAIN DATE (IF NEEDED), SUBJECT TO ACCEPTABLE WEATHER CONDITIONS AND AN ON-SITE INSPECTION ON THE DAY OF THE DISPLAY BY THE FIRE

MONDAY, APRIL 3, 2023, TOWNSHIP BOARD MINUTES – REGULAR MEETING
CHARTER TOWNSHIP OF DELTA

CHIEF OR HIS DESIGNEE. FURTHER, THAT THE TOWNSHIP MANAGER BE AUTHORIZED TO SIGN THE ATTACHED PERMIT & AGREEMENT WITH NIGHT MAGIC DISPLAYS.

TRUSTEE MOJICA SUPPORTED THE MOTION. THE MOTION PASSED 6-0.

9. St. Gerard Amusement & Entertainment Permit – May 5 & 6, 2023

TRUSTEE BREWER MOVED THAT THE DELTA TOWNSHIP BOARD GRANT AN AMUSEMENT AND ENTERTAINMENT LICENSE TO ST. GERARD'S CHURCH TO HOLD THEIR ANNUAL FESTIVAL. THE FESTIVAL WILL RUN BETWEEN THE HOURS OF 12:00 P.M., FRIDAY, MAY 5, 2023, AND CONCLUDING AT 11:59 P.M., SATURDAY, MAY 6, 2023, AND FURTHER

THE PERMIT IS GRANTED SUBJECT TO THE FOLLOWING STIPULATIONS:

- 1) THAT ALL OTHER TOWNSHIP ORDINANCES AND REGULATIONS BE ADHERED TO.
- 2) THAT THE FIRE MARSHAL AND ELECTRICAL INSPECTOR WILL PERFORM INSPECTIONS AS REQUIRED AFTER FESTIVAL SET UP.
- 3) APPLICANT MUST ADHERE TO THE 2015 INTERNATIONAL FIRE CODE REGARDING TENTS.
- 4) APPLICANT MUST ADHERE TO THE 2014 TENT DISPLAY ORDINANCE.
- 5) THE REQUIRED INSURANCE CERTIFICATE AND BOND SHALL BE ON FILE WITH THE CLERK PRIOR TO ISSUANCE OF PERMITS.
- 6) SECURITY FOR THE FESTIVAL MUST BE CERTIFIED THROUGH THE MASSACHUSETTS CROWD MANAGER COURSE PER DELTA TOWNSHIP FIRE DEPARTMENT. CERTIFICATION IS VALID FOR THREE YEARS.
- 7) FURTHER, THAT THE FEE FOR THE AMUSEMENT & ENTERTAINMENT LICENSE HAS BEEN WAIVED.
- 8) THE APPLICANT OF THE FESTIVAL SHALL BE RESPONSIBLE FOR ALL OPERATIONAL REQUIREMENTS STATED IN SECTION 6-16 OF THE AMUSEMENT & ENTERTAINMENT ORDINANCE.
- 9) THE APPLICANT OF THE FESTIVAL SHALL BE RESPONSIBLE FOR CONTAINING ALL PARKING FOR THE FESTIVAL WITHIN THE CHURCH PROPERTY.

XII. ITEMS REMOVED FROM CONSENT AGENDA FOR DISCUSSION

XIII. ITEMS ADDED TO AGENDA UNDER SECTION V. SET/ADJUST AGENDA

10. Millett Tower Down Pipe Replacement

MONDAY, APRIL 3, 2023, TOWNSHIP BOARD MINUTES – REGULAR MEETING
CHARTER TOWNSHIP OF DELTA

TREASURER FEDEWA MOVED THAT THE DELTA TOWNSHIP BOARD ACCEPTS THE PROPOSALS FROM E&L CONTRACTING TO REMOVE AND REPLACE THE 16” AND 20” DOWN PIPES AT MILLETT WATER TOWER AT A COST OF \$89,989.00. I FURTHER MOVE THAT THE TOWNSHIP BOARD AUTHORIZE THE TOWNSHIP MANAGER TO SIGN THE AUTHORIZATION FORMS.

TRUSTEE BOWEN SUPPORTED THE MOTION. THE MOTION PASSED 6-0.

XIV. OLD ITEMS OF BUSINESS

XV. NEW ITEMS OF BUSINESS

11. Case No. 11-22-08: Special Land Use Permit to allow for a tractor-trailer facility on a 10.22-acre undeveloped parcel on the northeast corner of Waverly Road and Old Lansing Road

AT THE RECOMMENDATION OF THE PLANNING COMMISSION, CLERK CLARK MOVED THAT THE DELTA TOWNSHIP BOARD APPROVE THE SPECIAL LAND USE PERMIT FOR A VEHICLE REPAIR FACILITY IN CASE NO. 11-22-08, FOR THE FOLLOWING REASONS:

1. THE USE MEETS ALL APPLICABLE GENERAL (SECTION 7.03) AND SPECIFIC USE STANDARDS (SECTION 8.61) FOR A TRUCK REPAIR FACILITY.
2. A SITE PLAN SHALL BE SUBMITTED FOR REVIEW BY THE PLANNING COMMISSION IN ACCORDANCE WITH THE PROVISION OF CHAPTER 6 OF THE DELTA TOWNSHIP ZONING ORDINANCE ILLUSTRATING COMPLIANCE WITH ALL THE TOWNSHIP’S APPLICABLE DEVELOPMENT REGULATIONS.

WITH THE FOLLOWING STIPULATIONS:

1. FAILURE OF THE APPLICANT TO COMPLY WITH ANY OF THE PROVISIONS REQUIRED BY THE ZONING ORDINANCE, OR ANY STIPULATIONS REQUIRED BY THE DELTA TOWNSHIP BOARD, SHALL CONSTITUTE GROUNDS FOR TERMINATION OF THIS PERMIT BY THE DELTA TOWNSHIP BOARD.
2. THE PROPOSED DEVELOPMENT WILL BE SUBJECT TO SITE PLAN REVIEW BY THE PLANNING COMMISSION.
3. THE NECESSARY AMENDMENTS TO THE TOWNSHIP’S TRUCK ROUTE ORDINANCE SHALL BE ADOPTED PRIOR TO THE COMMENCEMENT OF ANY CONSTRUCTION ACTIVITIES ON THE SUBJECT PARCEL.

MONDAY, APRIL 3, 2023, TOWNSHIP BOARD MINUTES – REGULAR MEETING
CHARTER TOWNSHIP OF DELTA

4. THE OLD LANSING ROAD DRIVEWAY SHALL BE LIMITED TO EGRESS ONLY AND ALLOW ONLY WESTBOUND TRAFFIC OUT OF THE DRIVEWAY ONTO OLD LANSING ROAD.

TRUSTEE BOWEN SUPPORTED THE MOTION. THE MOTION PASSED 6-0.

XVI. MANAGER’S REPORT – Brian Reed, Township Manager

Manager Reed presented his updates to the Township Board:

- Public education postcards were sent out and expected to hit mailboxes soon.
- North Canal house demolition took place last week.
- Introduction of Peter Menser, Delta Township’s new Economic Development Director.

XVII. COMMITTEE OF THE WHOLE

11. Utility Department Annual Report

Utility Director, Rick Kane, presented the Utility Department 2022 Annual Report to the Board.

XVIII. CLOSED SESSION

XIX. PUBLIC COMMENTS

XX. ADJOURNMENT –

Supervisor Fletcher adjourned the meeting at 7:41pm.

CHARTER TOWNSHIP OF DELTA

KENNETH R. FLETCHER, SUPERVISOR

MARY R. CLARK, TOWNSHIP CLERK

CHARTER TOWNSHIP OF DELTA
Public Meeting Room A
Delta Township Administration Building
7710 West Saginaw Highway
Lansing, MI 48917

**TOWNSHIP BOARD REGULAR MEETING MINUTES FOR
MONDAY, APRIL 10, 2023**

I. CALL TO ORDER

Supervisor Fletcher called the meeting to order at 6:00pm.

II. OPENING CEREMONIES – Pledge of Allegiance

III. ROLL CALL

Members Present: Supervisor Kenneth R. Fletcher, Clerk Mary R. Clark, Treasurer Dennis R. Fedewa, Trustee Fonda J. Brewer, Trustee Andrea M. Cascarilla, and Trustee Karen J. Mojica (arrived at 6:08pm)

Members Absent: Trustee Elizabeth S. Bowen

Others Present: Manager Brian T. Reed, Finance Director Courtney Nicholls, Township Engineer Ernie West, Lieutenant Elbert (Al) Sidel, Human Resource Director Kyla Moore, Assistant to the Manager/Communications Administrator Mary Worland, Planning Director Gary Bozek, Community & Economic Development Director Peter Menser, Utilities Director Rick Kane.

TREASURER FEDEWA MOVED TO EXCUSE TRUSTEE BOWEN AND TRUSTEE MOJICA FROM THE APRIL 10, 2023, REGULAR BOARD MEETING.

TRUSTEE CASCARILLA SUPPORTED THE MOTION. THE MOTION PASSED 5-0.

IV. PRESENTATIONS AND PROCLAMATIONS

V. SET/ADJUST AGENDA

SUPERVISOR FLETCHER MOVED TO APPROVE THE AGENDA AS AMENDED.

TRUSTEE BREWER SUPPORTED THE MOTION. THE MOTION PASSED 5-0.

VI. PUBLIC HEARING

MONDAY, APRIL 10, 2023, TOWNSHIP BOARD MINUTES – REGULAR MEETING
CHARTER TOWNSHIP OF DELTA

1. New Covenant Christian School Noise Waiver

SUPERVISOR FLETCHER MOVED THAT THE DELTA TOWNSHIP BOARD APPROVE THE REQUEST BY NEW COVENANT CHRISTIAN SCHOOL FOR A WAIVER OF THE NOISE ORDINANCE BETWEEN THE HOURS OF 10:30 A.M. AND 5:00 P.M. ON APRIL 30, 2022.

TRUSTEE CASCARILLA SUPPORTED THE MOTION. THE MOTION PASSED 5-0.

VII. COMMUNICATIONS

2. WRRF Update

3. Ultium Update

4. Notification of the Determination of Necessity – Bank Intercounty Drain

VIII. PUBLIC COMMENTS

Betsy Berger, 7727 Barfield Ln. – Spoke regarding the rezoning of the Broadbent development and concerns about drainage, privacy, and traffic.

Michael Beck, 312 Barrington Cr. – Spoke regarding the rezoning of the Broadbent development and concerns about total cost, traffic, and crime.

Tricia Schneeberger, 11389 Broadbent Rd. – Spoke regarding the rezoning for the Broadbent development and concerns about the type of zoning and drainage.

IX. INTRODUCTION OF ORDINANCES

X. PASSAGE OF ORDINANCES

XI. CONSENT AGENDA

TRUSTEE CASCARILLA MOVED TO APPROVE THE CONSENT AGENDA AS PRESENTED.

TRUSTEE BREWER SUPPORTED THE MOTION.

ROLL CALL:

AYES: SUPERVISOR FLETCHER, CLERK CLARK, TREASURER FEDEWA, TRUSTEE BREWER, TRUSTEE CASCARILLA AND TRUSTEE MOJICA

NAYS: NONE

ABSENT: TRUSTEE BOWEN

THE MOTION PASSED 6-0.

5. Bills and Financial Transactions

Bonds/Debt Payments	\$	
Payroll & Related	\$	411,667.30
Refunds	\$	881.77
Tax Distributions	\$	
Vendor Claims	\$	2,560,525.39
Total	\$	2,973,074.46

TRUSTEE CASCARILLA MOVED TO APPROVE THE CONSENT AGENDA AS PRESENTED.

TRUSTEE BREWER SUPPORTED THE MOTION. THE MOTION PASSED 6-0.

6. Sheriff Department Weighmaster Vehicle Reimbursement

TRUSTEE CASCARILLA MOVED THAT THE DELTA TOWNSHIP BOARD APPROVE THE PURCHASE OF THE WEIGHMASTER VEHICLE FOR USE OF THE DELTA PATROL WEIGHMASTER AND AUTHORIZES THE REIMBURSEMENT TO EATON COUNTY IN THE AMOUNT OF \$40,845.

TRUSTEE BREWER SUPPORTED THE MOTION. THE MOTION PASSED 6-0.

7. Additional Credited Service for Ryan Morrissey, Fire Department

TRUSTEE CASCARILLA MOVED THAT THE DELTA TOWNSHIP BOARD APPROVE THE PURCHASE OF THREE (3) MONTHS ADDITIONAL CREDITED SERVICE BY RYAN MORRISSEY AS PROVIDED BY THE MERS PLAN DOCUMENT AND ACCORDING TO THE FOLLOWING STIPULATIONS:

- IT IS UNDERSTOOD THAT CALCULATION OF THE ACTUARIAL COST IS BASED ON THE ASSUMPTIONS PROVIDED AND APPROVED BY THE MERS RETIREMENT BOARD ON THE DATE THE CALCULATION WAS PREPARED.
- ACTUAL FUTURE EVENTS AND EXPERIENCE MAY RESULT IN CHANGES DIFFERENT FROM THOSE ASSUMED, AND LIABILITY DIFFERENT FROM THAT ESTIMATED.

MONDAY, APRIL 10, 2023, TOWNSHIP BOARD MINUTES – REGULAR MEETING
CHARTER TOWNSHIP OF DELTA

- THE PURCHASE OF SERVICE CREDIT DOES NOT AFFECT VESTING FOR RETIREE HEALTH INSURANCE.
- THE EMPLOYEE (RYAN MORRISSEY) WILL BE RESPONSIBLE AND IS REQUIRED TO PAY THE FULL COST OF THE PURCHASE FOR THE CREDITED SERVICE.

XII. ITEMS REMOVED FROM CONSENT AGENDA FOR DISCUSSION

XIII. ITEMS ADDED TO AGENDA UNDER SECTION V. SET/ADJUST AGENDA

XIV. OLD ITEMS OF BUSINESS

XV. NEW ITEMS OF BUSINESS

XVI. MANAGER’S REPORT – Brian Reed, Township Manager

Manager Reed presented his updates to the Township Board:

- New edition of Delta Now has hit mailboxes.
- Along with Treasurer Fedewa, presenting tomorrow to the Board of the Friends of the Lansing River Trail.

XVII. COMMITTEE OF THE WHOLE

9. Planning Department Annual Report

Planning Director, Gary Bozek, presented the Planning Department 2022 Annual Report to the Board.

XVIII. CLOSED SESSION

XIX. PUBLIC COMMENTS

XX. ADJOURNMENT –

Supervisor Fletcher adjourned the meeting at 6:23pm.

CHARTER TOWNSHIP OF DELTA

KENNETH R. FLETCHER, SUPERVISOR

MARY R. CLARK, TOWNSHIP CLERK



Engineering Department

(517) 323-8540

TO: Supervisor Kenneth R. Fletcher and the Delta Township Board

**FROM: Brian Reed, Township Manager
 Ernie West, Township Engineer
 Rick Kane, Utility Director
 Courtney Nicholls, Finance Director**

DATE: April 25, 2023

**SUBJECT: Water Resource Recovery Facility
 Major Capital Improvements Phase 1
 Recommendations for Approval of Change Order No 4**

Background

On April 4, 2022 the Township Board approved the Water Resource Recovery Facility Major Capital Improvements Phase 1 Construction Phase Contracts, which included a deduct Change Order No 1 for the value proposal reductions. On February 20, 2023 the Township Board approved Change Order No 2. On March 20, 2023 the Township Board approved Change Order No 3. At this time, Change Order No 4 is being presented for your consideration.

The change order includes several items, which have all have been reviewed by staff, and staff are in agreement that these change items should be incorporated into the project. The items will be reviewed by EGLE SRF staff and verify eligibility to be applied to the SRF contingency funds for the project.

The following table identifies the recommended Change Order No. 4 amount.

WCD 07 - Control Building Hot Water Circulation	\$ 5,681.00	Omission: Fixtures greater than 50 feet from a water heater require a recirculation pump to meet plumbing code.
WCD 11 - Aeration Effluent Slide Gate Height	\$ 3,883.00	Omission: Slide gates require a height of 48 inches to isolate Final Clarifies from Aeration Tank, which is needed for WRRF operation
WCD 12 - Control Building - Utility Closet	\$ 4,748.78	Owner Request: Staff initiated design improvement to use available open space in the vestibule to add a utility closet for storage in this area.
WCD 13 - Control Building - Screen Wall Gate	\$ 18,959.00	Omission: Opening in masonry wall is required for air circulation around the air handling unit (AHU-1).
WCD 14 - Control Building - Lockers	\$ 3,643.00	Added Value: Locker layout did not fill the available space so lockers and filler sections are needed to fill Mud Room space allocated for lockers and provide additional locker capacity.
Change Order No 4 Total	\$ 36,914.78	



Project Budget Summary	
Original Contract Amount	\$73,776,000.00
Change Order No. 1	(\$699,318.00)
Change Order No. 2	\$38,161.19
Change Order No. 3	\$154,743.03
Previously Revised Contract Amount	\$73,269,589.22
Proposed Change Order No. 4	\$36,914.78
Revised Contract Amount	\$73,306,501.00
SRF Contingency Amount	\$4,714,635.00
Change Order Total to Date (CO 1 – 4)	(\$469,863.00)
Remaining Available Contingency Amount	\$5,184,134.00

Required Action

The following motion is offered for your consideration:

"I move that the Delta Township Board approve the proposed Change Order No. 4 with Commercial Contracting Corporation, increasing the contract for Phase 1 of the Water Resource Recovery Facility Major Capital Improvements Project by \$36,914.78 for a total of \$73,306,501.00; I further move, that the Township Manager be authorized and directed to execute the Change Order No 4 on behalf of the Township."

Staff will attend the May 1, 2023 Township Board Meeting to answer any questions or address any concerns of the Board. If there are any questions in the interim, please let us know. Thank you.

CONTRACTOR: Commercial Contracting Corporation
 4260 North Atlantic Boulevard
 Auburn Hills, MI 48326
 Attn: Frank Scheiderer
 OWNER: Delta Township

C.O. Number: 4
 Date: 18-Apr-23
 Project: DELTA TWP WRRF IMPROVEMENTS PHASE I
 Contract: 200-214200-20001
 SRF No. 5725-01

TO THE CONTRACTOR NAMED ABOVE:

Under the terms of this Agreement, and upon acceptance of the CONTRACTOR and approval of OWNER, ENGINEER recommends the following changes to the Agreement:

<u>Item No.</u>	<u>Description</u>	<u>Add/Deduct</u>	<u>Quantity</u>	<u>Unit Price</u>	<u>Amount</u>
WCD 07	Control Building - Hot Water Circulation	ADD	1 LS	\$5,681.00	\$5,681.00
WCD 11	Aeration Effluent Slide Gate Height	ADD	1 LS	\$3,883.00	\$3,883.00
WCD 12	Control Building - Utility Closet	ADD	1 LS	\$4,748.78	\$4,748.78
WCD 13	Control Building - Screen Wall Gate	ADD	1 LS	\$18,959.00	\$18,959.00
WCD 14	Control Building - Lockers	ADD	1 LS	\$3,643.00	\$3,643.00
Total This Change Order		ADD			\$36,914.78

REASON FOR CHANGE:

- WCD 07:** Recirculation pump and piping for fixtures greater than 50 feet from water heater.
- WCD 11:** Change gates F.110.1-.4 height from 36" to 48" to hydraulically isolate Final Clarifiers from Aeration Tanks.
- WCD 12:** Owner requested installation of closet in Vestibule for utility storage.
- WCD 13:** Double louvered gate required for air circulation at AHU-1 location.
- WCD 14:** Add 5 lockers and spacers to fill Mud Room wall space.

Original Contract Price	\$73,776,000.00
Change Order No. 1	(\$699,318.00)
Change Order No. 2	\$38,161.19
Change Order No. 3	\$154,743.03
This Change Order ADD	\$36,914.78
Revised Contract Price	\$73,306,501.00
Current Substantial Completion Date	2-Nov-24
Revised Substantial Completion Date	-
Current Final Completion Date	2-Dec-24
Revised Final Completion Date	-
Contract Time Extension	0 Days

The above is agreed to as full and complete compensation for the Work listed in the Change Order.

RECOMMENDED BY: Tetra Tech



DATE

4/18/2023

ACCEPTED BY:

Commercial Contracting Corporation
 Frank Scheiderer

DATE

April 26, 2023

APPROVED BY:

Delta Township

DATE



TETRA TECH

3497 Coolidge Road, East Lansing, MI 48823
Telephone: 517.316.3930

WORK CHANGE DIRECTIVE

DISTRIBUTION: Ernie West, P.E.
Rick Kane
Jennifer Bernardin
Tetra Tech File

TO: Frank Scheiderer
Commercial Contracting Corporation
4260 North Atlantic Blvd
Auburn Hills, MI 48326

PROJECT: DELTA TOWNSHIP
WRRF IMPROVEMENTS
PHASE I
200-214200-20001

DIRECTIVE NO.: 07

DATE: April 4, 2023

To prevent a possible delay in the work you are directed to proceed with the following changes in the work:

Furnish and install 100 LF of 3/4" Type L copper piping, a 1/2" recirculation pump, and insulate as needed to create a hot water recirculation loop in the Control Building.

Reason:

Fixtures greater than 50 LF from a water heater require a recirculation pump to meet plumbing code.

The contract amount and/or time will be adjusted by a future change order based on:

- Actual time and material costs plus OH&P
- An agreed sum to be added \$5,681.00
- An agreed sum to be deducted \$
- No change in contract price.
- No change in contract time.

A detailed breakdown is needed.
 has been received.

TETRA TECH, INC.

Recommended by: _____

Date 4/4/2023

CONTRACTOR: Commercial Contracting Corporation

Accepted by:  Frank Scheiderer

Date April 11, 2023

OWNER: Delta Township

Approved by: _____

Date _____



April 4, 2023

Tetra Tech
3297 Coolidge Road
East Lansing, MI 48823

Attention: Ms. Melissa Clough Hopkins, P.E.
Environmental Engineer

Regarding: TT Contract 200-214200-20001
Delta Township WRRF Major Capital Improvements Project
Quote for Hot Water Circulation Pump (PCO 27 REV1)

Dear Ms. Hopkins,

[THIS QUOTE SUPERSEDES PCO 27 DATED FEBRUARY 10, 2023]

During the installation of the copper water pipe in the Control Building, Allied Mechanical mentioned that the hot water pipe from the water heater (WH-1) to the fixtures is greater than 50 lineal foot. To meet the Michigan Plumbing Code, Chapter 6 Water Supply Distribution, 607.2 Hot and Tempered water supply to fixtures, we need to add a hot water recirculation pump. Even if the Water Heater is moved to a different location in the Mechanical Room the piping distance is still greater than 50 LF. The below is extra work not in the contract to add a hot water recirculation pump, pipe, and insulation.

Allied Mechanical Services

- Control Building Hot Water Recirc Pump = \$5,411.00
CCC Mark-up @ 5% = \$ 270.00
Total (PCO 27 REV1) = \$5,681.00

Conditions:

- See the attached Allied Quote dated April 4, 2023 (Ref: Allied quote was received attached to Submittal No. 74, dated February 6, 2023). CCC will submit the product data after the quote is approved by Delta.
- Please issue a change order.

Should you have any questions, please do not hesitate to contact me at 313-212-3486.

Sincerely,
Commercial Contracting Corporation

Frank Scheiderer
Project Manager/Estimator

cc: John Taormina, Mark Maloney, Anuj Patel, File: 3267 Delta WRRF

Downtown Detroit
28 West Adams Ave. #201
Detroit, Michigan 48226



COMMERCIAL CONTRACTING CORPORATION

Corporate Headquarters
4260 North Atlantic Boulevard
Auburn Hills, Michigan 48326
248.209.0500 | www.cccnetwork.com



Steel Fabrication
4590 Joslyn Road
Lake Orion, MI 48359



April 4, 2023

Commercial Contracting Corporation
Frank Scheiderer

RE: Control Building Hot Water Recirc Pump - Revised

(Due to previous proposal included taxes & Administrative cost)

The purpose for this proposal is due to the distance of hot water at use points and the need for a recirculation pump to include necessary pipe and fittings – which is not included in the Engineers IFC drawings.

Proposal includes:

- Material & Labor
 - Pump
 - Insulation
- Submittal of Pump

Cost: \$5,411.00

Pricing is firm for 30 days. Payment terms are net 30 days.

Sincerely,

Project Manager & Director of Virtual Design
Allied Mechanical Services, Inc.
5688 East ML Ave., Kalamazoo, MI 49048
(dreed@alliedmechanical.com)
Cell: (269) 207-4039

Allied Mechanical Services
Change Order Cost Summary

Job Name: Delta Township WWTP

Description: **Control Building Hot Water Recirc Pump and Piping**

Bulletin/CO Number _____

Date: Wednesday, March 1, 2023

REVISED

Material and Equipment			
Material	Cost	Quantity	Total
3/4" Type L copper Pipe x 100' @ approx. \$5 per ft	500.00	x 1.00	= 500.00
(50) 3/4" Fittings @ avg cost of approx. \$2.50 per fitting	125.00	x 1.00	= 125.00
(2) 3/4" sweat Circuit Setters @ \$111 ea.	222.00	x 1.00	= 222.00
Insulation @ approx. \$2 per foot	200.00	x 1.00	= 200.00
Pump	432.00	x 1.00	= 432.00
Support hardware material	200.00	x 1.00	= 200.00
Equipment	Cost	Quantity	Total
	0.00	x 0.00	= 0.00
	0.00	x 0.00	= 0.00
	0.00	x 0.00	= 0.00
	0.00	x 0.00	= 0.00
Total Material and Equipment:			1,679.00
Fee on Material and Equipment:			15% = 251.85
Total Material, Equipment and Fee:			1,930.85

Piping Labor							
	Base	+	Benefits	=	Rate	Hours	Total
Journeyman Pipefitter	40.29		23.83		64.12	x 46.00	= 2,949.52
Journeyman Pipefitter OT	60.44		23.83		84.27	x 0.00	= 0.00
Journeyman Pipefitter DT	80.58		23.83		104.41	x 0.00	= 0.00
Sheet Metal Journeyman	38.09		20.73		58.82	x 0.00	= 0.00
Sheet Metal Journeyman OT	57.14		20.73		77.87	x 0.00	= 0.00
Sheet Metal Journeyman DT	76.18		20.73		96.91	x 0.00	= 0.00
Sheet Metal Foreman	40.76		20.73		61.49	x 0.00	= 0.00
Sheet Metal Foreman OT	61.14		20.73		81.87	x 0.00	= 0.00
Sheet Metal Foreman DT	81.52		20.73		102.25	x 0.00	= 0.00
Sheet Metal General Foreman	41.52		20.73		62.25	x 0.00	= 0.00
Sheet Metal General Foreman OT	62.28		20.73		83.01	x 0.00	= 0.00
Sheet Metal General Foreman DT	83.04		20.73		103.77	x 0.00	= 0.00
Project Manager	N/A		N/A		110.00	x 0.00	= 0.00
Project Coordinator	N/A		N/A		70.00	x 0.00	= 0.00
Safety Director	N/A		N/A		68.00	x 0.00	= 0.00
Delivery Driver and Vehicle	N/A		N/A		60.00	x 0.00	= 0.00
NOTE: Sheet Metal \$1.50 Wage increase on 5-1-2023							
Total Piping Labor Hours:						46.00	2,949.52
Fee on Labor:						15%	442.43
Total Labor and Fee:							3,391.95

Subcontractors		
Vendor Name	Cost	
	0.00	
	0.00	
	0.00	
	0.00	
Total Sub Cost:		0.00
Fee on Subs:		5% = 0.00
Total Cost and Fee:		0.00

Change Order Totals		
		Totals
Small Tools Fee	3%	88.49
Warranty Adder	0%	0.00
Total Material and Equipment		1,930.85
Total Labor		3,391.95
Total Subcontractors		0.00
Change Order Subtotal		5,411.28
Bond Adder	0%	0.00
Change Order Grand Total		\$5,411.28



SUBMITTAL

JOB: Major Capital Improvements Phase 1

JOB NO.: 20938

DATE: 02/06/2023



TO: Commercial Contracting Corporation



4260 N Atlantic Blvd



Auburn Hills, MI 48326



SPEC SECTION: N/A



SUBMITTAL NO.: AMS 074



SUBMITTAL TITLE: Control Building Hot Water Recirc Pump



REVISION NO.:

MANUFACTURER: Bell & Gossett



REMARKS: Cost Proposal is included to do the work, please see page 6.



Allied Mechanical Services, Inc.	
<input checked="" type="checkbox"/>	REVIEWED
<input type="checkbox"/>	APPROVED
<input type="checkbox"/>	(without) Exception
<input type="checkbox"/>	(with) Exception
<input type="checkbox"/>	REJECTED
<input type="checkbox"/>	Resubmission (is) Required
<input type="checkbox"/>	Resubmission (is not) Required
CHECKED BY: Don Reed	
DATE: February 6, 2023	
Approval is for design only. Contractor is responsible for dimensions, quantities, and coordination with other trades. Approval is subject to all contract requirements and does not authorize any changes involving additional cost unless stated in separate letter or change order.	

JOB: Delta WWTP

REPRESENTATIVE: Nathan Oliver

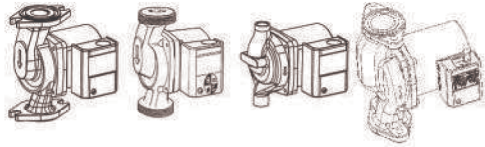
UNIT TAG:
ENGINEER:
CONTRACTOR:
ORDER NO.
SUBMITTED BY:
APPROVED BY:
DATE: 1/30/2023
DATE:
DATE:

Lead-Free[†] Bronze and Stainless Steel Bodied System Lubricated Circulators

DESCRIPTION

A series of in-line wet rotor circulation pumps designed specifically for quiet operation in open (potable) water systems. These pumps have lead-free[†] bronze or stainless steel bodies.

Automatic Timer and Aquastat accessories are available. (See Submittal A-128A for details).

CONSTRUCTION MATERIALS

Pump Body: Impeller: Noryl
 Shaft: Ceramic

NBF: Lead-Free[†] Bronze
 SSF: Stainless Steel

Bearings: Carbon

OPERATING DATA

Maximum Working Pressure: 150 psi (10.3 Bar)
 Minimum Operating Temperature: 40°F (5°C)

Maximum Operating Temperature
 NBF-25, NBF-33, NBF-36, NBF-45: 225°F (107°C)
 All Others: 230°F (110°C)

[†]Contains less than 0.25% Lead content by weight on wetted surfaces.

MODEL NUMBER	PART NUMBER	CONNECTION	APPROX. SHPG. WT. Lbs. (Kg)	STANDART 60 CYCLE 115 VOLT SINGLE PHASE			TAGGING INFORMATION	QUANTITY
				WATTS	F.L. AMPS	RPM		
NBF-8S/LW	103257LF	1/2" Sweat	9.0 (4.1)	39	0.38	2800		
NBF-9U/LW	103258LF	Union (See Following Page)	9.3 (4.2)	41	0.40	2800		
SSF-9U/LW	103360LF	Union (See Following Page)	9.3 (4.2)	41	0.40	2800		
 NBF-10S/LW	103259LF	1/2" Sweat	9.0 (4.1)	52	0.46	2800		1
NBF-12U/LW	103261LF	Union (See Following Page)	9.3 (4.2)	55	0.48	2800		
SSF-12U/LW	103361LF	Union (See Following Page)	9.3 (4.2)	55	0.48	2800		
NBF-12F/LW	103260LF	Flange 3/4, 1, 1-1/4, 1-1/2	9.5 (4.3)	55	0.48	2800		
SSF-12F/LW	103358LF	Flange 3/4, 1, 1-1/4, 1-1/2	9.5 (4.3)	55	0.48	2800		
NBF-18S	103316LF	1/2" Sweat	9.0 (4.1)	90	0.74	3000		
NBF-22U	103255LF	Union (See Following Page)	9.3 (4.2)	92	0.80	2940		
SSF-22U	103362LF	Union (See Following Page)	9.3 (4.2)	92	0.80	2940		
NBF-22	103252LF	Flange 3/4, 1, 1-1/4, 1-1/2	9.5 (4.3)	92	0.80	2940		
SSF-22	103357LF	Flange 3/4, 1, 1-1/4, 1-1/2	9.5 (4.3)	92	0.80	2940		
NBF-25*	103418LF	Flange 3/4, 1, 1-1/4, 1-1/2	10.4 (4.7)	125	1.10	2950		
NBF-33	103351LF	Flange 3/4, 1, 1-1/4, 1-1/2	10.4 (4.7)	125	1.10	2950		
NBF-36*	103401LF	Flange 3/4, 1, 1-1/4, 1-1/2	13.1 (6.0)	270	2.30	3300		
NBF-45*	103405LF	Flange 1, 1-1/4, 1-1/2	14.5 (6.6)	270	2.30	3300		

*3-speed circulators

TYPICAL SPECIFICATIONS

The contractor shall furnish and install in-line circulating pumps as illustrated on the plans and in accordance with the following specifications:

- The pumps shall be of the horizontal system lubricated type specifically designed and guaranteed for quiet operation.
- Pump to be suitable for _____°F (_____)°C [choose one: 225°F (107°C) for NBF-25, NBF-33, NBF-36, NBF-45 or 230°F (110°C) for all other circulators] operation at 150 psig (10.3 Bar) working pressure.
- The pumps shall have a ceramic shaft supported by carbon bearings. Bearings are to be lubricated by the circulating fluid.

- Pump body shall be lead-free bronze for NBF circulators or stainless steel for SSF circulators.
- Motor stator to be isolated from circulating fluid through use of stainless steel can. Rotor to be sheathed in stainless steel.
- Motors shall be non-overloading at any point on the pump curve. NBF-36 & NBF-45 to have built-in thermal protection. All other motors to have built-in impedance protection.
- NBF-25 has an optional check valve.

Pumps to have a capacity of _____GPM at _____ foot head when powered by 115 volt, 60 cycle single phase electrical supply.

All pumps are to be Xylem - Bell & Gossett Model _____.

System Lubricated Circulators

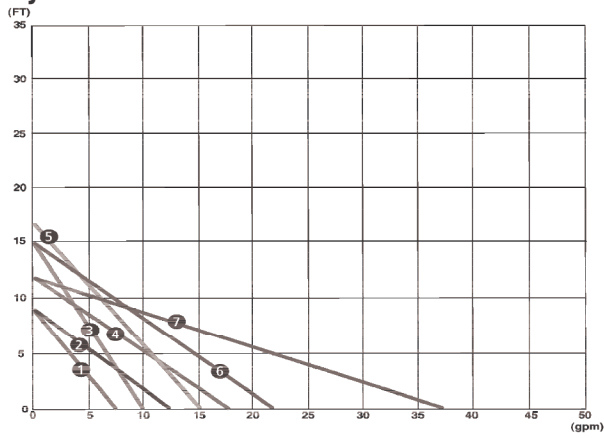

- 1 NBF-8S/LW
- 2 NBF-9U/LW
SSF-9U/LW
- 3 NBF-10S/LW
- 4 NBF-12U/LW
SSF-12U/LW
NBF-12F/LW
SSF-12F/LW
- 5 NBF-18S
- 6 NBF-22
SSF-22
NBF-22U
SSF-22U
- 7 NBF-33

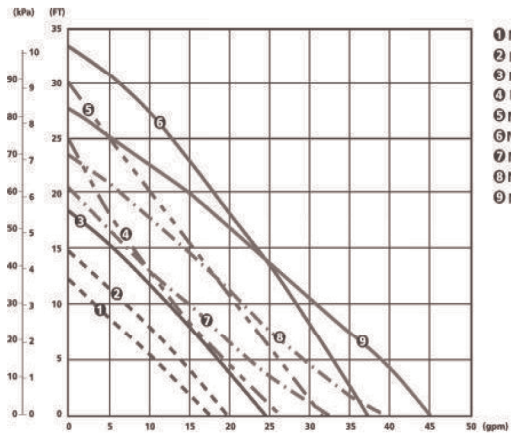

- 1 NBF-25 Speed 1
- 2 NBF-25 Speed 2
- 3 NBF-25 Speed 3
- 4 NBF-36 Speed 1
- 5 NBF-36 Speed 2
- 6 NBF-36 Speed 3
- 7 NBF-45 Speed 1
- 8 NBF-45 Speed 2
- 9 NBF-45 Speed 3

HALF UNION CONNECTIONS

For NBF-9U/LW, NBF-12U/LW, NBF-22U, SSF-9U/LW, SSF-12U/LW, SSF-22U

MODEL NUMBER	PART NUMBER	DESCRIPTION (SETS OF 2)
UC-1/2S	113203LF	1/2" Bronze Union Sweat
UC-3/4S	113201LF	3/4" Bronze Union Sweat
UC-3/4NPT	113202LF	3/4" Bronze Union NPT Female

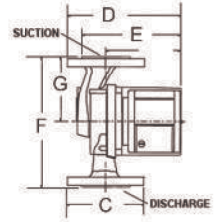
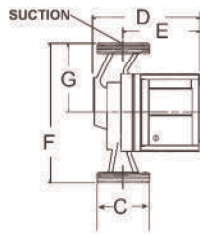
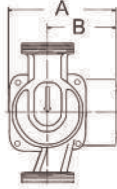
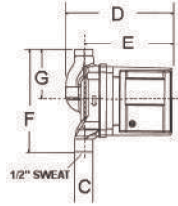
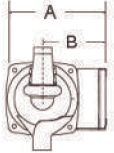
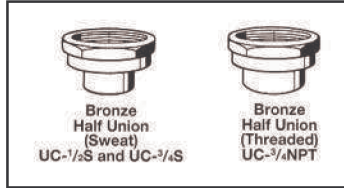

MODEL	PART NUMBER	A in (mm)	B in (mm)	C in (mm)	D in (mm)	E in (mm)	F in (mm)	G in (mm)
NBF-8S/LW	103257LF	4-7/8 (124)	3-3/16 (81)	1/2 (13)	5-7/32 (132)	4-9/32 (109)	5 (127)	2-1/2 (63)
NBF-9U/LW	103258LF	4-7/8 (124)	3-3/16 (81)	1-1/4 (32)	5-1/16 (129)	3-11/16 (93)	6-1/8 (156)	3-1/16 (78)
SSF-9U/LW	103360LF	4-7/8 (124)	3-3/16 (81)	1-1/4 (32)	5-1/16 (129)	3-11/16 (93)	6-1/8 (156)	3-1/16 (78)
NBF-10S/LW	103259LF	4-7/8 (124)	3-3/16 (81)	1/2 (13)	5-7/32 (132)	4-9/32 (109)	5 (127)	2-1/2 (63)
NBF-12U/LW	103261LF	4-7/8 (124)	3-3/16 (81)	1-1/4 (32)	5-1/16 (129)	3-11/16 (93)	6-1/8 (156)	3-1/16 (81)
SSF-12U/LW	103361LF	4-7/8 (124)	3-3/16 (81)	1-1/4 (32)	5-1/16 (129)	3-11/16 (93)	6-1/8 (156)	3-1/16 (78)
NBF-12F/LW	103260LF	4-7/8 (124)	3-3/16 (81)	3-3/16 (81)	5-9/16 (141)	3-11/16 (93)	6-3/8 (162)	3-3/16 (82)
SSF-12F/LW	103358LF	4-7/8 (124)	3-3/16 (81)	3-3/16 (81)	5-9/16 (141)	3-11/16 (93)	6-3/8 (162)	3-3/16 (82)
NBF-18S	103316LF	4-7/8 (124)	3-3/16 (81)	1/2 (13)	5-7/32 (132)	4-9/32 (109)	5 (127)	2-1/2 (63)
NBF-22U	103255LF	4-7/8 (124)	3-3/16 (81)	1-1/4 (32)	5-1/16 (129)	3-11/16 (93)	6-1/8 (156)	3-1/16 (78)
SSF-22U	103362LF	4-7/8 (124)	3-3/16 (81)	1-1/4 (32)	5-1/16 (129)	3-11/16 (93)	6-1/8 (156)	3-1/16 (78)
NBF-22	103252LF	4-7/8 (124)	3-3/16 (81)	3-3/16 (81)	5-9/16 (141)	3-11/16 (93)	6-3/8 (162)	3-3/16 (82)
SSF-22	103357LF	4-7/8 (124)	3-3/16 (81)	3-3/16 (81)	5-9/16 (141)	3-11/16 (93)	6-3/8 (162)	3-3/16 (82)
NBF-25*	103418LF	5-1/8 (130)	3-3/16 (81)	3-3/16 (81)	6-3/16 (157)	4-7/8 (124)	6-3/8 (162)	2-1/2 (63)
NBF-33	103351LF	4-7/8 (124)	3-3/16 (81)	3-3/16 (81)	6-3/16 (157)	3-11/16 (94)	6-3/8 (162)	3-3/16 (82)
NBF-36*	103401LF	5-3/4 (146)	3-9/16 (91)	3-3/16 (81)	6-3/16 (157)	5-3/8 (137)	6-3/8 (162)	3-3/16 (82)
NBF-45*	103405LF	5-3/4 (146)	3-9/16 (91)	3-7/16 (87)	7-3/8 (187)	5-1/2 (140)	8-1/2 (216)	4-1/4 (108)

Dimensions are subject to change. Not to be used for construction purposes unless certified.

Companion Flanges Available in Sizes: 3/4", 1", 1-1/4", and 1-1/2"

* 3-speed circulators

Xylem Inc.
8200 N. Austin Avenue
Morton Grove, IL 60053
Phone: (847)966-3700
Fax: (847)965-8379
www.bellgossett.com



Bell & Gossett is a trademark of Xylem Inc. or one of its subsidiaries.
ESP-REP v2022.07 © 2014 Xylem Inc.

Order Number	
1472717	
Order Date	Page
01/30/2023 15:58:23	1 of 1

Bill To:

Allied Mechanical Services
 3860 Roger B. Chaffee Memorial Drive SE
 Grand Rapids, MI 49548

Ship To:

Allied Mechanical Services
 3860 Roger B. Chaffee Memorial Drive SE
 Grand Rapids, MI 49548

616-669-4800

Customer ID: 17946

<i>PO Number</i>					<i>Freight</i>		<i>Taker</i>		
					Full Freight Allowed		NOLIVER		
<i>Quantities</i>					<i>Item ID</i>		<i>Pricing</i>	<i>Unit</i>	<i>Extended</i>
<i>Ordered</i>	<i>Allocated</i>	<i>Remaining</i>	<i>UOM</i>	<i>Unit Size</i>	<i>Disp.</i>	<i>Item Description</i>	<i>UOM</i>	<i>Price</i>	<i>Price</i>
							<i>Unit Size</i>		
1.00	0.00	1.00	EA			NBF10S/LW	EA	432.0000	432.00
				1.0		NEW RED FOX BRONZE CIRCULATOR 115V - LOW WATT SWEAT CONNECT	1.0		

Total Lines: 1

SUB-TOTAL: 432.00
TAX: 0.00
AMOUNT DUE: **432.00**

U.S. Dollars

RL Deppmann shall not be liable for any delay, loss, damage or retention caused by acts or circumstances beyond its control including, without limitation, delayed shipments from manufacturers, delay of carriers, factory strikes or lockouts, civil or military authority, priority regulations, insurrection or riot, war, acts of terrorism, action of the elements, forces of nature, or by any cause beyond its control.

Credit card charges are limited to \$10,000 per project.

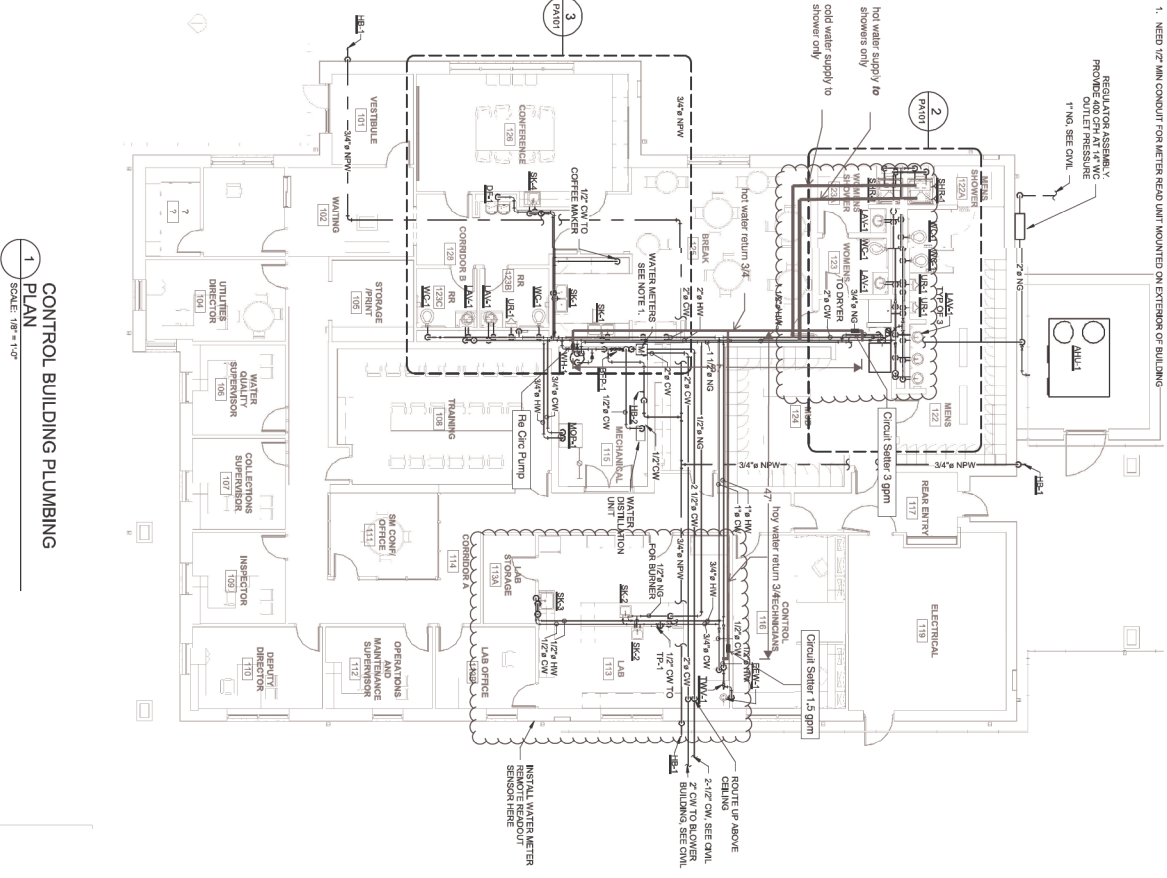

1 CONTROL BUILDING PLUMBING PLAN
SCALE: 1/8" = 1'-0"

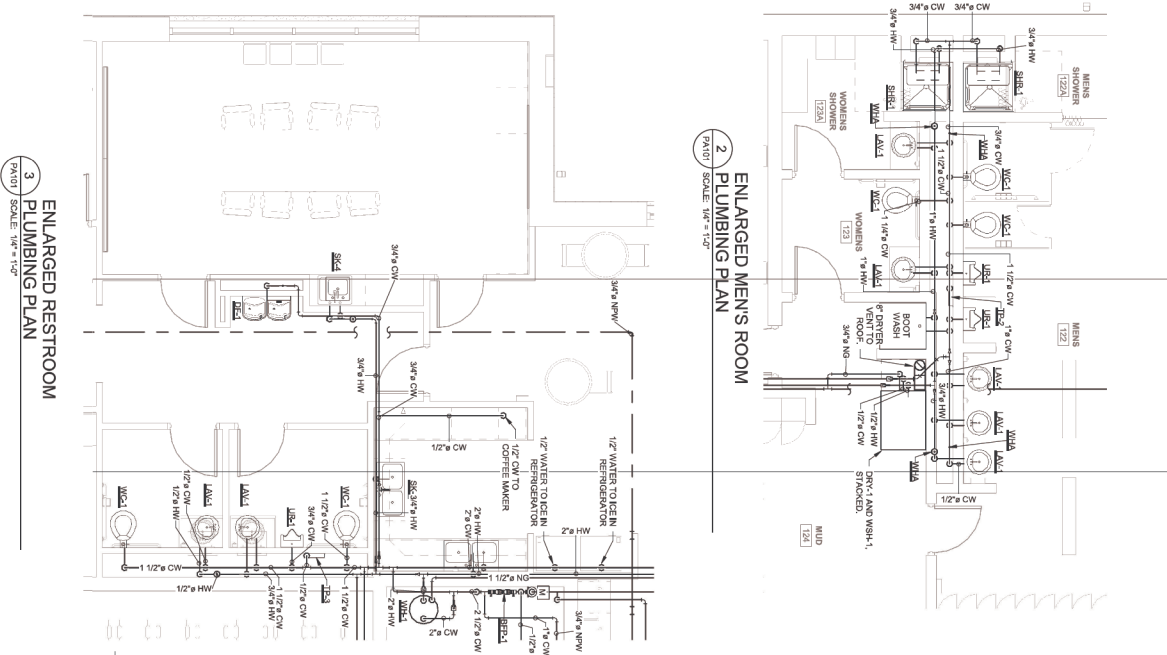

2 ENLARGED MEN'S ROOM PLUMBING PLAN
SCALE: 1/8" = 1'-0"



3 ENLARGED RESTROOM PLUMBING PLAN
SCALE: 1/8" = 1'-0"

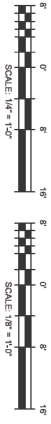

KEY PLAN
SCALE: 1/8" = 1'-0"

GENERAL NOTES:
1. NEED 1/2" MIN. CONDUIT FOR METER HEAD UNIT MOUNTED ON EXTERIOR OF BUILDING

<p>TETRA TECH ENGINEERING BUSINESS NO. 2429</p> <p>www.tetrattech.com 3497 COOLIDGE ROAD EAST LANSING, MI 48823 TEL: (617) 316.9390 FAX: (517) 484.8140</p>	<p>DELTA TOWNSHIP</p>	PROJ: 200-214200-20001 DRSN: TTB DRWN: TTB CHKD: LER	DELTA TOWNSHIP, MICHIGAN WWTP MAJOR CAPITAL IMPROVEMENTS PHASE I CONTROL BUILDING PLUMBING PLAN	MARK: 1 DATE: 06/06/22 DESCRIPTION: ISSUED FOR CONSTRUCTION BY:
		PA101		
		Copyright: Tetra Tech		
		Bar measures 1 inch, otherwise drawing is not to scale		



January 11, 2023

Commercial Contracting Corporation
Frank Scheiderer

RE: Control Building Hot Water Recirc Pump

The purpose for this proposal is due to the distance of hot water at use points and the need for a recirculation pump to include necessary pipe and fittings – which is not included in the Engineers IFC drawings.

Proposal includes:

- Material & Labor
 - Pump
 - Insulation
- Submittal of Pump

Cost: \$7,355.00

Pricing is firm for 30 days. Payment terms are net 30 days.

Sincerely,

Don Reed, Project Manager & Director of Virtual Design
Allied Mechanical Services, Inc.
5688 East ML Ave., Kalamazoo, MI 49048
(dreed@alliedmechanical.com)
Cell: (269) 207-4039

Original

Allied Mechanical Services
Change Order Cost Summary

Job Name: Delta Township WWTP

Description: **Control Building Hot Water Recirc Pump and Piping**

Bulletin/CO Number _____

Date: Friday, February 3, 2023

Material and Equipment			
Material	Cost	Sales Tax	Total
3/4" Type L copper Pipe x 100' @ approx. \$5 per ft	500.00	x 1.60	= 800.00
(50) 3/4" Fittings @ avg cost of approx. \$2.50 per fitting	125.00	x 1.60	= 200.00
(2) 3/4" sweat Circuit Setters @ \$111 ea.	222.00	x 1.60	= 355.20
Insulation @ approx. \$2 per foot	200.00	x 1.60	= 320.00
Pump	432.00	x 1.60	= 691.20
Support hardware material	200.00	x 1.60	= 320.00
Equipment	Cost	Quantity	Total
	0.00	x 0.00	= 0.00
	0.00	x 0.00	= 0.00
	0.00	x 0.00	= 0.00
	0.00	x 0.00	= 0.00
Total Material and Equipment:			2,686.40
Fee on Material and Equipment:			15% 402.96
Total Material, Equipment and Fee:			3,089.36

Piping Labor					
	Base	+ Profits	= Rate	Hours	Total
Journeyman Pipefitter	40.29	23.83	64.12	x 46.00	= 2,949.52
Journeyman Pipefitter OT	60.44	23.83	84.27	x 0.00	= 0.00
Journeyman Pipefitter DT	80.58	23.83	104.41	x 0.00	= 0.00
Sheet Metal Journeyman	38.09	20.73	58.82	x 0.00	= 0.00
Sheet Metal Journeyman OT	57.11	20.73	77.87	x 0.00	= 0.00
Sheet Metal Journeyman DT	76.18	20.73	96.91	x 0.00	= 0.00
Sheet Metal Foreman	40.74	20.73	61.49	x 0.00	= 0.00
Sheet Metal Foreman OT	61.44	20.73	81.87	x 0.00	= 0.00
Sheet Metal Foreman DT	81.52	20.73	102.25	x 0.00	= 0.00
Sheet Metal General Foreman	41.50	20.73	62.25	x 0.00	= 0.00
Sheet Metal General Foreman OT	62.28	20.73	83.01	x 0.00	= 0.00
Sheet Metal General Foreman DT	83.04	20.73	103.77	x 0.00	= 0.00
Project Manager	N/A	N/A	110.00	x 5.00	= 550.00
Project Coordinator	N/A	N/A	70.00	x 3.00	= 210.00
Safety Director	N/A	N/A	68.00	x 0.00	= 0.00
Delivery Driver and Vehicle	N/A	N/A	60.00	x 0.00	= 0.00
Total Piping Labor Hours:					54.00 3,709.52
Fee on Labor:					15% 556.43
Total Labor and Fee:					4,265.95

NOTE: Sheet Metal \$1.50 Wage increase on 5-1-2023

Subcontractors		
Vendor Name	Cost	
	0.00	
	0.00	
	0.00	
	0.00	
Total Sub Cost:		0.00
Fee on Subs:		5% 0.00
Total Cost and Fee:		0.00

Change Order Totals		
		Totals
Small Tools Fee	0%	0.00
Warranty Adder	0%	0.00
Total Material and Equipment		3,089.36
Total Labor		4,265.95
Total Subcontractors		0.00
Change Order Subtotal		7,355.31
Bond Adder	0%	0.00
Change Order Grand Total		\$7,355.31



TETRA TECH

3497 Coolidge Road, East Lansing, MI 48823
Telephone: 517.316.3930

WORK CHANGE DIRECTIVE

DISTRIBUTION: Ernie West, P.E.
Rick Kane
Jennifer Bernardin
Tetra Tech File

TO: Frank Scheiderer
Commercial Contracting Corporation
4260 North Atlantic Blvd
Auburn Hills, MI 48326

PROJECT: DELTA TOWNSHIP
WRRF IMPROVEMENTS
PHASE I
200-214200-20001

DIRECTIVE NO.: 11

DATE: April 4, 2023

To prevent a possible delay in the work you are directed to proceed with the following changes in the work:
Furnish four Aeration Tank effluent slide gates, F.110.1 through .4, as 36" W x 48" H in lieu of 36" x 36".

Reason:

Height of 48" slide gate will isolate Final Clarifiers from Aeration Tank as needed for WRRF operation.

The contract amount and/or time will be adjusted by a future change order based on:

- Actual time and material costs plus OH&P
- An agreed sum to be added \$ 3,883.00
- An agreed sum to be deducted \$ _____
- No change in contract price.
- No change in contract time.

A detailed breakdown is needed.
 has been received.

TETRA TECH, INC.

Recommended by: _____

Date 4/4/2023

CONTRACTOR: Commercial Contracting Corporation

Accepted by:  Frank Scheiderer

Date April 11, 2023

OWNER: Delta Township

Approved by: _____

Date _____



March 28, 2023

Tetra Tech
3297 Coolidge Road
East Lansing, MI 48823

Attention: Ms. Melissa Clough Hopkins, P.E.
Environmental Engineer

Regarding: TT Contract 200-214200-20001 (CCC Job No. 3267)
Delta Township WRRF Major Capital Improvements Project
Quote to change HydroGate sizes (PCO 32)

Dear Ms. Hopkins,

The below is extra work not in the contract to furnish four (4) 36" W X 48" H slide gate valves in lieu of the 36" X 36" slide gates located in the new Aeration Tank effluent chamber (Ref: slide gate nos. F110.1, F110.2, F110.3, and F110.4). This is beneficial to Delta Township's Operators for better control of flow and to isolate the downstream clarifiers.

Allied Mechanical Services, Inc.

Change HydroGate Size =		\$ 3,698.00
	CCC Mark-up @ 5% =	\$ 185.00
	Total (PCO 32) =	\$ 3,883.00

Conditions:

- Refer to the attached Allied quote dated March 6, 2023 and back-up
- Please issue a change order to proceed
- There is about a 16-week lead time for the slide gates

Should you have any questions, please do not hesitate to contact me at 313-212-3486.

Sincerely,
Commercial Contracting Corporation

Frank Scheiderer
Project Manager/Estimator

cc: John Taormina, Mark Maloney, Anuj Patel, File: 3267 Delta WRRF

Downtown Detroit
28 West Adams Ave. #201
Detroit, Michigan 48226



COMMERCIAL CONTRACTING CORPORATION

Corporate Headquarters
4260 North Atlantic Boulevard
Auburn Hills, Michigan 48326
248.209.0500 | www.cccnetwork.com



Steel Fabrication
4590 Joslyn Road
Lake Orion, MI 48359



March 6, 2022

Commercial Contracting Corporation
Frank Scheiderer

RE: Change of HydroGate Sizes

Per CCC submittal 146 (AMS046) and email correspondence, the following is the cost increase difference of changing the gate sizing of four gates.

- Manufacture/Vendor cost: \$3,216.00
- AMS 15% markup cost: \$482.00

Clarifications:

- Please see the attached documentation.

Lump Sum Cost: \$3,698.00

Pricing is firm for 30 days. Payment terms are net 30 days.

Sincerely,

Don Reed

Don Reed, Project Manager & Director of Virtual Design
Allied Mechanical Services, Inc.
5688 East ML Ave., Kalamazoo, MI 49048
(dreed@alliedmechanical.com)
Cell: (269) 207-4039

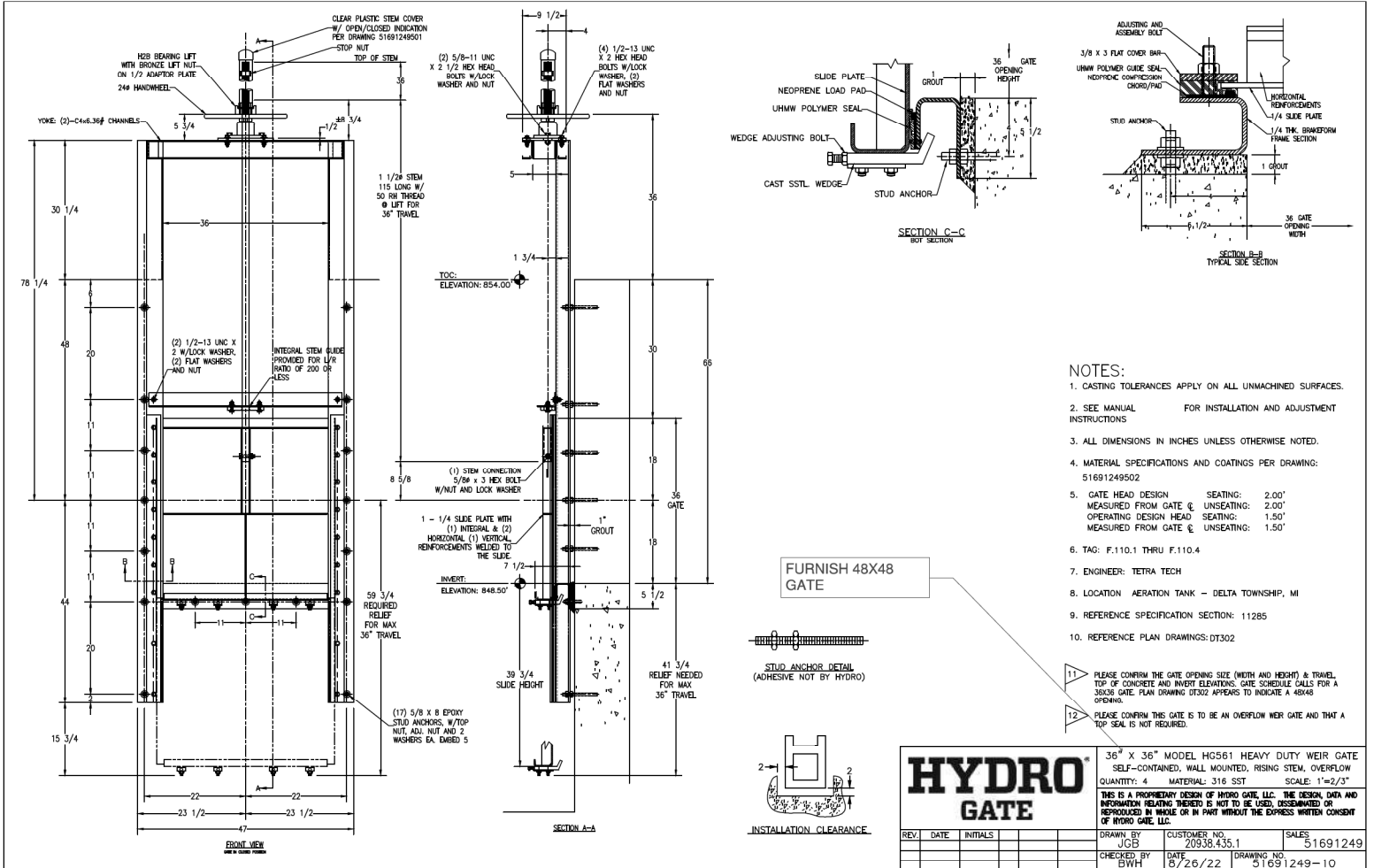

- NOTES:**
1. CASTING TOLERANCES APPLY ON ALL UNMACHINED SURFACES.
 2. SEE MANUAL FOR INSTALLATION AND ADJUSTMENT INSTRUCTIONS
 3. ALL DIMENSIONS IN INCHES UNLESS OTHERWISE NOTED.
 4. MATERIAL SPECIFICATIONS AND COATINGS PER DRAWING: 51691249502
 5. GATE HEAD DESIGN SEATING: 2.00'
MEASURED FROM GATE & UNSEATING: 2.00'
OPERATING DESIGN HEAD SEATING: 1.50'
MEASURED FROM GATE & UNSEATING: 1.50'
 6. TAG: F.110.1 THRU F.110.4
 7. ENGINEER: TETRA TECH
 8. LOCATION: AERATION TANK - DELTA TOWNSHIP, MI
 9. REFERENCE SPECIFICATION SECTION: 11285
 10. REFERENCE PLAN DRAWINGS: DT302

FURNISH 48X48 GATE

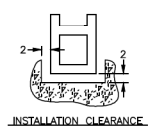
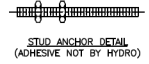

HYDRO GATE

36" X 36" MODEL HC561 HEAVY DUTY WEIR GATE
 SELF-CONTAINED, WALL MOUNTED, RISING STEM, OVERFLOW
 QUANTITY: 4 MATERIAL: 316 SST SCALE: 1"=2'/3"

THIS IS A PROPRIETARY DESIGN OF HYDRO GATE, LLC. THE DESIGN DATA AND INFORMATION RELATING HERETO IS NOT TO BE USED, REPRODUCED OR REPRODUCED IN WHOLE OR IN PART WITHOUT THE EXPRESS WRITTEN CONSENT OF HYDRO GATE, LLC.

REV.	DATE	INITIALS			

DRAWN BY JCB	CUSTOMER NO. 20338.435.1	SALES 51691249
CHECKED BY BWH	DATE 5/26/22	DRAWING NO. 51691249-10

Don Reed

From: Roger Anderson
Sent: Monday, March 6, 2023 2:03 PM
To: Don Reed
Subject: FW: Delta Gate



ALLIED MECHANICAL
SERVICES

Roger Anderson
Project Manager

Office: 269-978-4158
Mobile: 269-998-3713



From: Alex Myers <amyers@alliedmechanical.com>
Sent: Tuesday, January 24, 2023 12:35 PM
To: Roger Anderson <randerson@alliedmechanical.com>; Don Reed <dreed@alliedmechanical.com>
Subject: FW: Delta Gate



ALLIED MECHANICAL
SERVICES

Alex Myers
Project Superintendent

Mobile: 269.876.2429



From: Hopkins, Melissa <melissa.hopkins@tetrattech.com>
Sent: Tuesday, January 24, 2023 9:08 AM
To: Alex Myers <amyers@alliedmechanical.com>
Subject: Fwd: Delta Gate

Alex, see below please

Get [Outlook for iOS](#)

From: Bode, Brent <Brent.Bode@tetrattech.com>
Sent: Tuesday, January 24, 2023 7:59:43 AM

To: Hopkins, Melissa <melissa.hopkins@tetrattech.com>

Subject: Delta Gate

Melissa

See if AMS has an idea on the cost to make the aeration tank effluent gates 36" W x 48" H. The issue is we need the height to be able to isolate a clarifier downstream

Brent G. Bode, P.E. | Water/Wastewater Engineer

Direct: 517.316.3942 | Cell: 616.262.4203 | Main: 517.316.3930 Fax: 517.484.8140

brent.bode@tetrattech.com

Tetra Tech | *Leading with Science*[®]

3497 Coolidge Road | East Lansing, MI 48823 | tetrattech.com

This message, including any attachments, may include privileged, confidential and/or inside information. Any distribution or use of this communication by anyone other than the intended recipient is strictly prohibited and may be unlawful. If you are not the intended recipient, please notify the sender by replying to this message and then delete it from your system.

Not Hydrogate's Final Drawing. Final Drawing will be submitted for Record when available.

All Anchor Locations Subject to change Based on Hydrogate's final Drawing

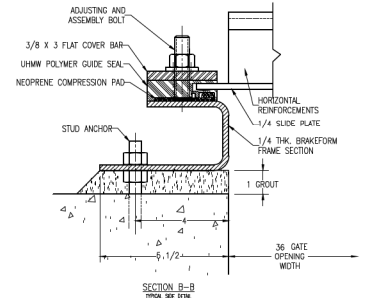
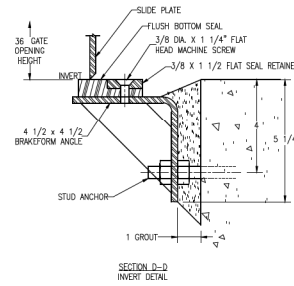
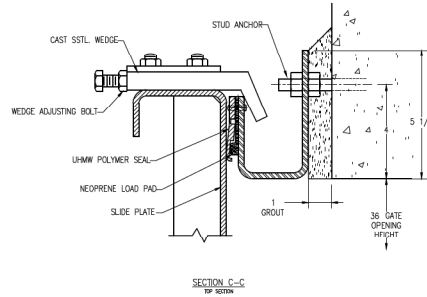
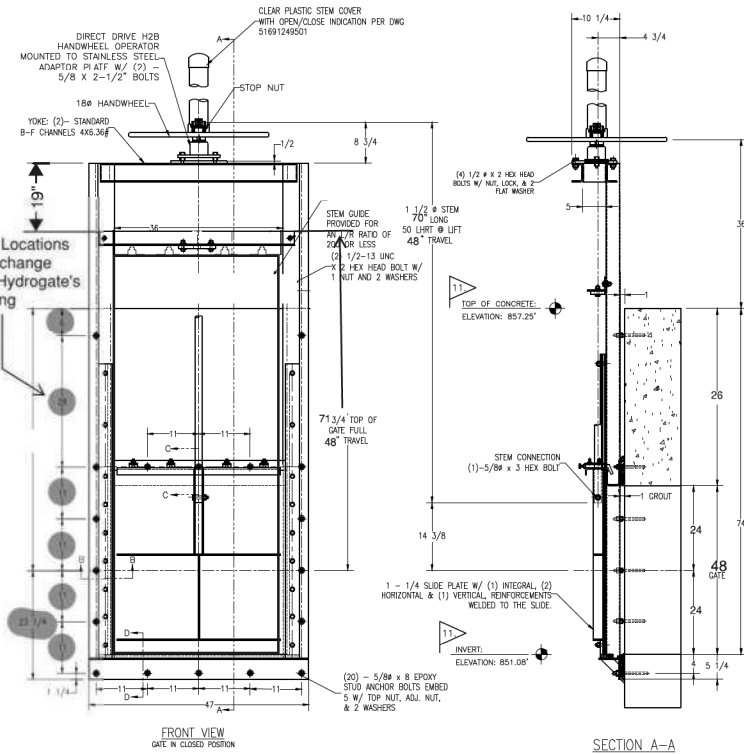

NOTES:

- CASTING TOLERANCES APPLY ON ALL UNMACHINED SURFACES.
- SEE MANUAL, HG561 FOR INSTALLATION AND ADJUSTMENT INSTRUCTIONS.
- ALL DIMENSIONS IN INCHES UNLESS OTHERWISE NOTED.
- MATERIAL SPECIFICATIONS AND COATINGS PER DRAWING: 51691249502
- GATE HEAD DESIGN SEATING: 10.00'
MEASURED FROM GATE Q UNSEATING: 10.00'
OPERATING DESIGN HEAD SEATING: 4.67'
MEASURED FROM GATE Q UNSEATING: 4.67'
- TAG: F105.1
- ENGINEER: TETRA TECH.
- LOCATION: PRIMARY TANK - DELTA TOWNSHIP, MI
- REFERENCE SPECIFICATIONS SECTION: 11285
- REFERENCE PLAN DRAWINGS: DP101
- PLEASE CONFIRM THE GATE SIZE & TRAVEL, THE TOP OF CONCRETE AND INVERT ELEVATIONS, AS WELL AS THE MOUNTING CONFIGURATION.

HYDRO GATE			48"		
			36" X 36" MODEL HG561 SLIDE GATE WALL MOUNTED, SELF-CONTAINED, RISING STEM		
QUANTITY: 1			MATERIAL: 316 SST	SCALE: 1"=3/5"	
THIS IS A PROPRIETARY DESIGN OF HYDRO GATE, LLC. THE DESIGN DATA AND INFORMATION RELATING THERETO IS NOT TO BE USED, REPRODUCED OR REPRODUCED IN WHOLE OR IN PART WITHOUT THE EXPRESS WRITTEN CONSENT OF HYDRO GATE, LLC.					
REV.	DATE	INITIALS	DRAWN BY: DWH	CUSTOMER NO. 20338.435.1	SALES 51691249
			CHECKED BY:	DATE 5/26/22	DRAWING NO. 51691249-07



Hydro Gate Sales
 12000 E. 47th Ave
 Suite 200
 Denver, CO 80239

phone: 303-288-7873
 fax: 303-287-8531
 hydrogate.com

Change Order # 1 revised

DATE: February 21, 2023
TO: Kaitlyn Nowlen
FIRM: Allied Mechanical Services,
PROJECT: Delta Twp, MI

PAGES: 1
ORDER #: 51691249
FROM: Susan Dye
PHONE: 303-374-2184
EMAIL: sdye@hydrogate.com
Hydro Gate Project Engineer: Branden, Hempelman

Drawing Number	DESCRIPTION	Unit Adder	Extended Adder
51691249-10	Change 4 – 36” x 36” HG561 stainless steel Weir Gates to 4 – 36” x 48” HG561 Stainless steel Weir Gates.	\$ 804.00	\$ 3,216.00

TOTAL ADDER: \$ 3,216.00

** Price does not include Tax **

*** Items listed above are on hold until this Change Order has been resolved ***

Please confirm your acceptance of this Change Order by signing and returning a copy to Hydro Gate.

Change Order accepted by _____ Date _____



TETRA TECH

3497 Coolidge Road, East Lansing, MI 48823
Telephone: 517.316.3930

WORK CHANGE DIRECTIVE

DISTRIBUTION: Ernie West, P.E.
Rick Kane
Jennifer Bernardin
Tetra Tech File

TO: Frank Scheiderer
Commercial Contracting Corporation
4260 North Atlantic Blvd
Auburn Hills, MI 48326

PROJECT: DELTA TOWNSHIP
WRRF IMPROVEMENTS
PHASE I
200-214200-20001

DIRECTIVE NO.: 12

DATE: April 4, 2023

To prevent a possible delay in the work you are directed to proceed with the following changes in the work:

Furnish and install a utility closet in the Control Building between the Vestibule and Waiting areas.

Furnish a door and frame in utility closet to match interior Control Building openings.

Furnish and install a Type D light fixture in the utility closet.

Furnish additional carpet materials for utility closet and Waiting areas.

Reason:

Utility closet requested by Owner to make the most of the Vestibule footprint.

The contract amount and/or time will be adjusted by a future change order based on:

- Actual time and material costs plus OH&P
- An agreed sum to be added \$ 4,748.78
- An agreed sum to be deducted \$
- No change in contract price.
- No change in contract time.

A detailed breakdown is needed.
 has been received.

TETRA TECH, INC.

Recommended by: _____ Date 4/4/2023

CONTRACTOR: Commercial Contracting Corporation

Accepted by:  Frank Scheiderer Date April 11, 2023

OWNER: Delta Township

Approved by: _____ Date _____



Consider every angle®

March 10, 2023

Tetra Tech
3297 Coolidge Road
East Lansing, MI 48823

Attention: Ms. Melissa Clough Hopkins, P.E.
Environmental Engineer

Regarding: TT Contract 200-214200-20001 (CCC Job No. 3267-00)
Delta Township WRRF Major Capital Improvements Project
Vestibule Wall Relocation and Closet Addition (PCO 26)

Dear Ms. Hopkins,

Below is the pricing breakdown to move the wall in the vestibule and add the closet as requested. Please see the succeeding pages for backup documentation.

Allen Supply:	
New door frame and slab =	\$2,324.00
Lansing Tile & Mosaic:	
Additional carpet/materials =	\$440.69
Superior Electric:	
Additional materials/labor =	\$1,471.56
Murray Painting:	
Additional materials/labor =	No Charge
CCC:	
Additional drywall/labor:	
(1) Taper Foreman @ \$71.60 x 4 hours =	\$286.40
Drywall Materials =	<u>No Charge</u>
Subtotal:	\$4,522.65
CCC Markup @ 5% =	<u>\$ 226.13</u>
Total (PCO 26) =	\$4,748.78

If you have any questions, or need additional information, please let me know.

Regards,

Mark Maloney | Project Manager
COMMERCIAL CONTRACTING CORPORATION

Downtown Detroit
28 West Adams Ave. #201
Detroit, Michigan 48226



COMMERCIAL CONTRACTING CORPORATION

Corporate Headquarters
4260 North Atlantic Boulevard
Auburn Hills, Michigan 48326
248.209.0500 | www.ccnetwork.com



Steel Fabrication
4590 Joslyn Road
Lake Orion, MI 48359



Consider
every angle®

4260 N. Atlantic Blvd. Auburn Hills, Michigan 48326

O: 248.209.0500 | C: 810.288.8563 | <https://www.cccnetwork.com>

Downtown Detroit
28 West Adams Ave. #201
Detroit, Michigan 48226



COMMERCIAL CONTRACTING CORPORATION

Corporate Headquarters
4260 North Atlantic Boulevard
Auburn Hills, Michigan 48326
248.209.0500 | www.cccnetwork.com



Steel Fabrication
4590 Joslyn Road
Lake Orion, MI 48359

Maloney, Mark

From: Steve Ridley <steve@allensupply.net>
Sent: Wednesday, February 8, 2023 3:45 PM
To: Maloney, Mark
Subject: [EXTERNAL]RE: Additional Door Frame Quote

Follow Up Flag: Follow up
Flag Status: Flagged

To duplicate opening #118 which is a non-fire rated opening.

\$2,324.00 tax included

Steve Ridley
Allen Supply
2800 Universal Drive
Saginaw MI 48603
989-799-2525 Office
989-239-4429 Cell

From: Maloney, Mark <mark.maloney@cccnetwork.com>
Sent: Wednesday, February 8, 2023 3:29 PM
To: Steve Ridley <steve@allensupply.net>
Subject: Additional Door Frame Quote

Steve,

HRC is wanting to add a closet in the control building and I need to price out the CO. Can you give me a breakdown cost of the frame, slab and standard hardware?

Thank you!



Consider
every angle®

Mark Maloney | Project Manager

COMMERCIAL CONTRACTING CORPORATION

4260 N. Atlantic Blvd. Auburn Hills, Michigan 48326

O: 248.209.0500 | C: 810.288.8563 | <https://www.cccnetwork.com>

Detroit Free Press Top Work Place 2017-2022

This email originated from outside the organization. Do not click links or open attachments unless you recognize the sender and know the content is safe.

Superior Electric
of Lansing, Inc.



Superior Results
Since 1950

212 West Sheridan Road
Lansing, MI 48906

Phone: 517-485-7125
Fax: 517-485-1507



**Commercial
Industrial**

Delta Twp. W.w.t.p.

02-22-23

COMMERCIAL CONTRACTING CORPORATION

4260 N. Atlantic Blvd. Auburn Hills, Michigan 48326

Frank Scheiderer Project Mgr.

frank.scheiderer@cccnetwork.com

Cell 313 212 3486

Mark Maloney | Project Manager

mark.maloney@cccnetwork.com

C: 810.288.8563

Add 1 type "D" fixtures in control bldg. vestibule closet area

Total Cost \$1,471.56

General Conditions:

- 1) All applicable taxes are included in this submission.

Respectfully,

Accepted By,

Michael J. McCrackin, Project Manager

Authorized Agent

Date

	Description	Quantity	Total Material
1	3/4" GRC (GALV)	20	54.80
2	1/2" STEEL FLEX	10	12.57
3	1/2" STL FLEX CONN	2	8.43
4	#10 THHN	240	80.67
5	4x2-1/8" SQ BOX COMB KO	1	5.85
6	4" SQ 2G PL-RING 3/4" RISE	1	3.72
7	20A 120-277V S/P SW (SG)	1	6.04
8	add fixture type D	1	156.50
9	adjust asbuilts and or panel directory	1	0.00
	Totals	277	328.58

	Labor Type	Hours	Rate \$	Total
1	Electrician	7.04	88.55	883.31
	Totals	7.04	88.55	883.31

	General Expenses	Total
12	COURIER	48.20
	Totals	48.20

	Final Pricing	Calculated (%)	Calculated (\$)
	Database Material (Extension)		328.58
	Material Tax	6.000	19.71
	Material Total		348.29
	Direct Labor		883.31
	Labor Total		883.31
	General Expenses		45.00
	Total Cost		1,276.60
	General Expenses Overhead	4.000	1.80
	Total Overhead	0.141	1.80
	General Expenses Markup	2.991	1.40
	Adjustment Markup	15.000	191.76
	Total Markup	15.110	193.16
	Selling Price		1,471.56
	Final Price		1,471.56



MARK	DATE	DESCRIPTION
BY	06/02/22	ISSUED FOR CONSTRUCTION

DELTA TOWNSHIP, MICHIGAN
 WTPF MAJOR CAPITAL IMPROVEMENTS
 PHASE I
 CONTROL BUILDING
 FLOOR PLAN

PROJ: 20027-0000-0001
 DESK: J. HUNSDUCKER
 DRAWN: M. STANKEK
 CHKD: Q. BHAGI

AA101

- ### GENERAL NOTES - FLOOR PLAN
- REFER TO SHEETS **AA100** AND **AA101** FOR GENERAL NOTES, SYMBOLS, LEGENDS AND STANDARDS AND TYPICAL MOUNTING HEIGHTS, SCHEDULE.
 - REFER TO SHEET **AA101** FOR DOOR TYPES, FRAME TYPES, AND DOOR SCHEDULE.
 - REFER TO SHEETS **AA101** FOR PARTITION TYPES AND DETAILS.
 - REFER TO SHEET **AA101** FOR ROOM FINISH SCHEDULE AND DETAILS.
 - REFER TO SHEET **AA101** FOR STORAGE SCHEDULE AND DETAILS.

- ### KEYNOTES
- PREFINISHED ALUMINUM DOWNSPOUTS DISCHARGED TO PIPE HUBS AT GRADE TO UNDERGROUND PIPING. SEE CIVIL.
 - PREFINISHED ALUMINUM COPING CAP.
 - CONCRETE LANDING AT EXTERIOR DOOR. SEE CIVIL.
 - SCREEN WALL.
 - EYEWASH. SEE PLUMBING FOR CONNECTIONS.
 - SEWING WITH HANGERS ROD BELOW. MOUNT AT ELEVATION 3'-2" AND 8'-7" FROM FLOOR.
 - SURFACE MOUNTED FREE-EXTINGUISHER CABINET.
 - BRACKET MOUNTED FREE-EXTINGUISHER.
 - 8" X 8" CHASE AT ISLAND.

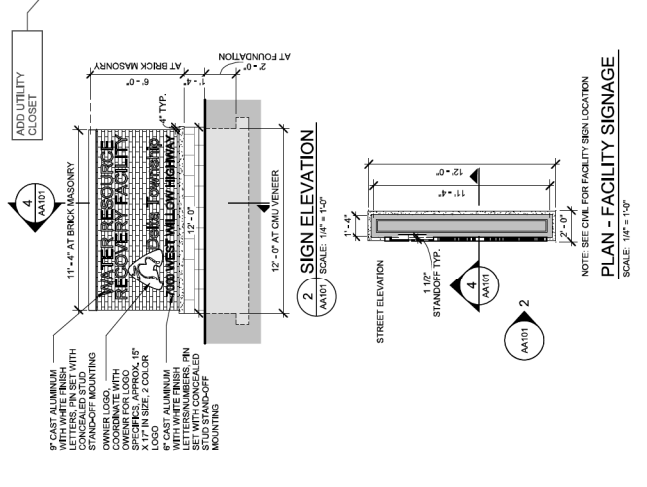
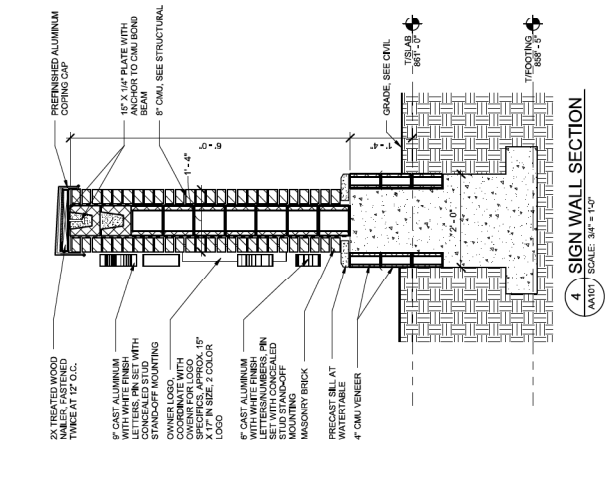
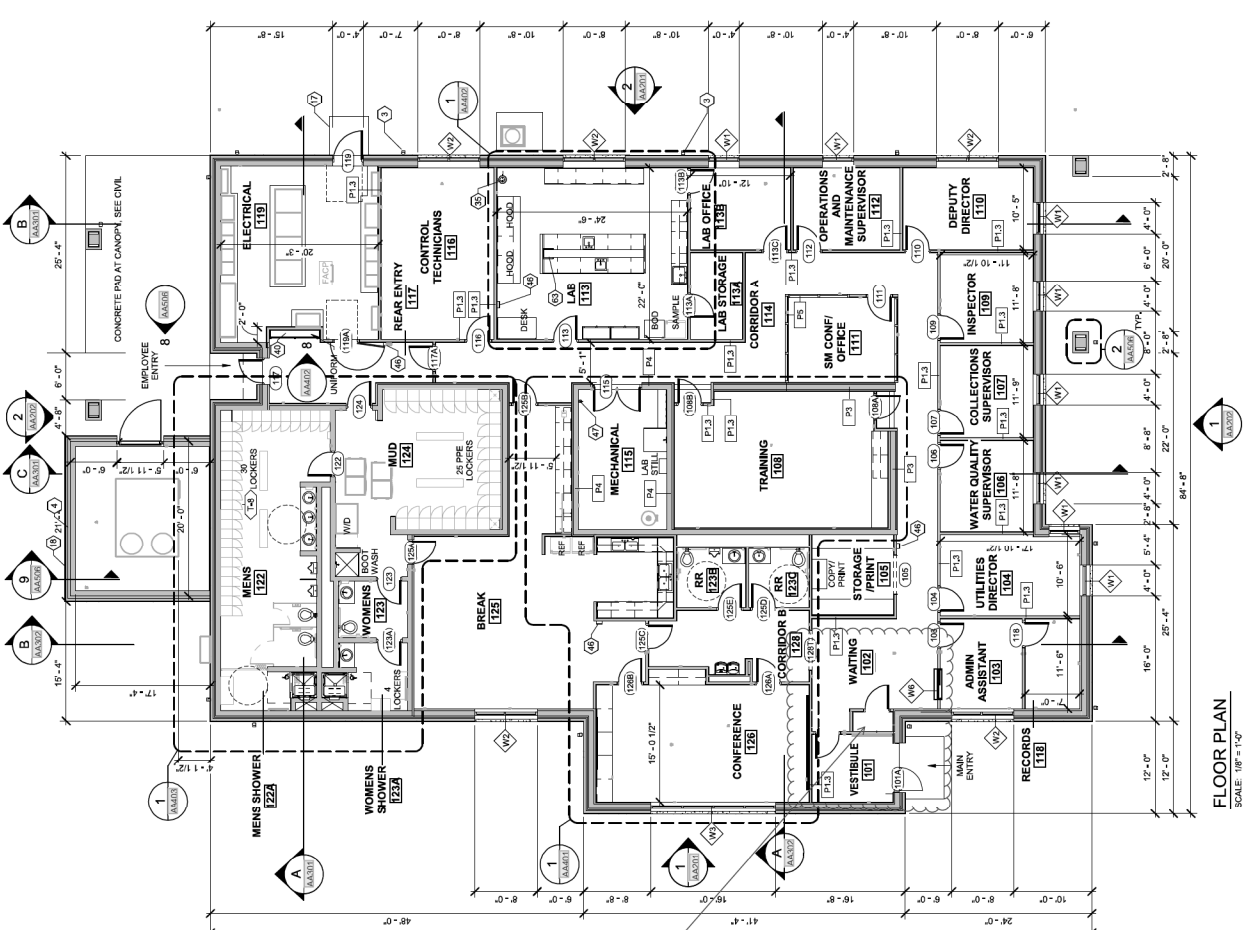
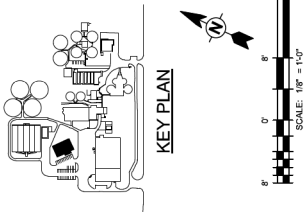

PLAN - FACILITY SIGNAGE
 NOTE: SEE CIVIL FOR FACILITY SIGN LOCATION
 SCALE: 1/4" = 1'-0"



TETRA TECH

3497 Coolidge Road, East Lansing, MI 48823
Telephone: 517.316.3930

WORK CHANGE DIRECTIVE

DISTRIBUTION: Ernie West, P.E.
Rick Kane
Jennifer Bernardin
Tetra Tech File

TO: Frank Scheiderer
Commercial Contracting Corporation
4260 North Atlantic Blvd
Auburn Hills, MI 48326

PROJECT: DELTA TOWNSHIP
WRRF IMPROVEMENTS
PHASE I
200-214200-20001

DIRECTIVE NO.: 13

DATE: April 4, 2023

To prevent a possible delay in the work you are directed to proceed with the following changes in the work:
Furnish and install a double louvered gate at the Control Building HVAC screen wall as directed by RFI 58.

Reason:

Opening required for air circulation around the air handling unit (AHU-1).

The contract amount and/or time will be adjusted by a future change order based on:

- Actual time and material costs plus OH&P
- An agreed sum to be added \$18,959.00
- An agreed sum to be deducted \$
- No change in contract price.
- No change in contract time.

A detailed breakdown is needed.
 has been received.

TETRA TECH, INC.

Recommended by: _____

Date 4/4/2023

CONTRACTOR: Commercial Contracting Corporation

Accepted by:  Frank Scheiderer

Date April 11, 2023

OWNER: Delta Township

Approved by: _____

Date _____



Consider every angle®

April 3, 2023

Tetra Tech
3297 Coolidge Road
East Lansing, MI 48823

Attention: Ms. Melissa Clough Hopkins, P.E.
Environmental Engineer

Regarding: TT Contract 200-214200-20001 (CCC Job No. 3267-00)
Delta Township WRRF Major Capital Improvements Project
RFI #58 Screen Wall Demo/Gate Addition (PCO 29)

Dear Ms. Hopkins,

Below is the pricing breakdown to remove a portion of the screen wall, cut the foundation down to 8" to install gate posts, install gate base plates, pour back sloped concrete over the 8" and install a new double gate on the west end of the screen wall per RFI #58 response.

Ametco:		
12'8" wide x 7' high double swing gate w/ materials and hardware:		\$14,930.00
Tax:		<u>\$ 896.00</u>
Subtotal:		\$15,826.00
CCC Markup @ 15%		<u>\$ 2,274.00</u>
Total:		\$18,200.00

CCC Install Labor:		
(1) Journeyman Ironworker @ \$92.30 x 4 hours =		\$369.20
(1) Foreman Ironworker @ \$97.53 x 4 hours =		<u>\$390.12</u>
Total:		\$759.00

Total (PCO 29) Price: \$18,959.00

If you have any questions, or need additional information, please let me know.

Regards,

Mark Maloney | Project Manager
COMMERCIAL CONTRACTING CORPORATION

4260 N. Atlantic Blvd. Auburn Hills, Michigan 48326
O: 248.209.0500 | C: 810.288.8563 | <https://www.cccnetwork.com>

Downtown Detroit
28 West Adams Ave. #201
Detroit, Michigan 48226



COMMERCIAL CONTRACTING CORPORATION

Corporate Headquarters
4260 North Atlantic Boulevard
Auburn Hills, Michigan 48326
248.209.0500 | www.cccnetwork.com



Steel Fabrication
4590 Joslyn Road
Lake Orion, MI 48359



4326 Hamann Pkwy
PO Box 1210
Willoughby, OH 44096
800-321-7042 (440) 951-4300
Fax (440) 951-2542
www.ametco.com
jtaylor@ametco.com

TO: COMMERCIAL CONTRACTING CORPORATION
ATTENTION: MARK MALONEY
JOB: WWTP MAJOR CAPITAL IMPROVMENTS PHASE 1 REV 1

DATE: 2-10-23
PHONE: 810.288.8563
EMAIL: mark.maloney@cccnetwork.com

THANK YOU FOR YOUR RECENT INQUIRY; WE ARE PLEASED TO QUOTE AS FOLLOWS:

AMETCO ALUMINUM ECLIPSE 100 DESIGN FENCING

EXTRUDED INCLINED MAIN BARS ON 1-13/16" CENTERS. CROSSBARS ARE ON CENTERS UP TO 18". LOUVERS ARE ARRANGED FOR 100% DIRECT VISUAL SCREENING AND POWDER COATED FROM 1 OF AMETCO'S 14 STANDARD COLORS.

THE FOLLOWING ARE INCLUDED:

(1)- 12' 8" WIDE X 7' HIGH DOUBLE SWING GATE
GATES INCLUDE POSTS, FRAME(S), HINGES, PANELS, PADLOCKABLE SLIDE AND CANE BOLTS

LOT PRICE \$14,930.00

(1)- 6' WIDE X 7' HIGH SINGLE SWING GATE
GATES INCLUDE POSTS, FRAME(S), HINGES, PANELS, PADLOCKABLE SLIDE AND CANE BOLTS

LOT PRICE \$10,830.00

QUOTE EXPIRES IN 30 DAYS

- * F.O.B. WILLOUGHBY, OH - **FREIGHT ALLOWED TO: MI**
- * ALLOW **2-3 WEEKS** FOR SHOP DRAWINGS AFTER P.O. IS RECEIVED. SHIPS **12-14 WEEKS** AFTER DRAWING APPROVAL.
- * THE STANDARD LEAD TIME IS BASED ON MATERIAL AVAILABILITY AT THE TIME OF APPROVAL.
- * ABOVE LEAD TIMES DO NOT APPLY IF ANY NON-STANDARD SERVICES/ITEMS ARE NEEDED/REQUESTED.
- * A MINIMUM MIX CHARGE APPLIES FOR ANY CUSTOM POWDER COLOR NOT SHOWN ON AMETCO'S STANDARD COLOR CHART AND LEAD TIMES ARE TBD. A CHIP SAMPLE NEEDS TO BE PROVIDED TO AMETCO TO MATCH AND PRICE.
- * EXCLUSIONS INCLUDE BUT NOT LIMITED TO STATE ENGINEERING SERVICES, INSTALLATION, TAXES, PIPE SLEEVES, OPERATORS, MOCK UPS AND ANCHOR BOLTS. IF NOT LISTED IN INCLUDED DESCRIPTION, ITEM(S) WILL NOT BE FURNISHED. FIELD DIMENSION VERIFICATION TO BE DONE BY CONTRACTOR - NOT AMETCO.
- * PRICES SHOWN ARE SUBJECT TO CHANGE WITHOUT NOTICE. ALL QUOTES ARE FOR STANDARD AMETCO DESIGNS UNLESS OTHERWISE SPECIFIED - NOT DELEGATED DESIGN.
- * CANCELLATION FEES APPLY. STORAGE FEES APPLY IF MATERIALS ARE NOT SHIPPED AFTER 30 DAYS OF BEING COMPLETED.

Jake Taylor

-WARRANTY-

AMETCO MFG CORP CERTIFIES THAT ITS FENCING SYSTEMS ARE FREE FROM DEFECTS IN MATERIAL AND WORKMANSHIP FOR A PERIOD OF 1 YEAR. THE 20 YEAR LIMITED WARRANTY GUARANTEES THE POLYESTER COATED GALVANIZED FINISH AGAINST CRACKS, PEELS, OR BLISTERS. ANY MODIFICATIONS MADE TO PRODUCT WILL IMMEDIATELY VOID THE WARRANTY.

MICHIGAN

JUNE 2022 THRU MAY 2023

Last Updated: 6/7/22

CLASSIFICATION	BASE RATE	VAC.	S/T TOTAL	S/T INS. & TAXES	O/T & D/T INS. & TAXES	S/T O/T	ADDER PORTION O/T	SMALL TOOLS	0.00% S/T COST	15.00% CCC M/U	STRAIGHT TIME RATE	1-1/2 TIME RATE	DOUBLE TIME RATE	EXPIRATION DATE	
															FRINGES
CARPENTER GEN. FOREMAN - CS	42.29	0.48	42.77	7.09	3.61	34.17	0.00	0.00	0.00	84.03	12.60	96.63	119.82	143.01	687
CARPENTER FOREMAN - CS	37.29	0.48	37.77	6.26	3.19	31.25	0.00	0.00	0.00	75.28	11.29	86.57	107.05	127.53	687
CARPENTER JOURNEYMAN - CS	35.90	0.48	36.38	6.03	3.07	30.43	0.00	0.00	0.00	72.84	10.93	83.77	103.50	123.22	687
CEMENT MASON - FOREMAN	33.23	6.35	39.58	6.56	3.34	20.38	4.39	8.77	0.00	66.52	9.98	76.50	102.35	128.19	514
CEMENT MASON - JOURNEYMAN	31.23	6.29	37.52	6.22	3.17	20.38	4.39	8.77	0.00	64.12	9.62	73.74	98.47	123.20	514
TAPERS - FOREMAN	35.10	2.60	37.70	6.25	3.19	18.31	0.00	0.00	0.00	62.26	9.34	71.60	92.05	112.49	
TAPERS-JOURNEYMAN	32.85	2.60	35.45	5.88	3.00	18.31	0.00	0.00	0.00	59.64	8.95	68.59	87.82	107.04	
IRONWORKER REINFORCED - FOREMAN - CS	33.43	4.26	37.69	6.25	3.18	32.43	15.86	31.72	0.00	76.37	11.46	87.83	124.13	160.42	
IRONWORKER REINFORCED - JRNMYMAN - CS	31.43	4.01	35.44	5.88	2.99	31.32	15.31	30.61	0.00	72.64	10.90	83.54	118.06	152.58	
IRONWORKER GRT LKS STRUCT GENERAL FOREMAN	37.50	6.12	43.62	7.23	3.69	36.21	17.34	34.67	0.00	87.06	13.06	100.12	141.11	182.10	
IRONWORKER GRT LKS STRUCT FOREMAN	36.50	5.96	42.46	7.04	3.59	35.31	16.88	33.76	0.00	84.81	12.72	97.53	137.44	177.34	
IRONWORKER GRT LKS STRUCT JRNMYMAN	34.50	5.64	40.14	6.65	3.39	33.47	15.97	31.93	0.00	80.26	12.04	92.30	130.03	167.76	
LABORER FOREMAN - CS/JS	27.00	4.00	31.00	5.14	2.62	17.32	5.08	10.15	0.00	53.46	8.02	61.48	83.37	105.25	
LABORER - CS/JS	25.75	4.00	29.75	4.93	2.51	17.32	5.05	10.15	0.00	52.00	7.80	59.80	80.98	102.21	
OPERATOR FOREMAN - REG ENG - CS - AGC	36.21	5.43	41.54	6.90	3.52	25.29	0.00	0.00	0.00	73.83	11.07	84.90	107.48	130.06	
OPERATOR - REG ENG - CS - AGC	35.21	5.28	40.49	6.71	3.42	25.29	0.00	0.00	0.00	72.49	10.87	83.36	105.32	127.27	
OPERATOR - FORK LIFT - CS - AGC	33.72	5.06	38.78	6.43	3.28	25.29	0.00	0.00	0.00	70.50	10.57	81.07	102.10	123.13	
IRONWORKER GEN. FOREMAN - IS CONVEYOR	37.50	6.12	43.62	7.23	3.69	36.21	17.34	34.67	0.00	87.06	13.06	100.12	141.11	182.10	
IRONWORKER FOREMAN - IS CONVEYOR	36.50	5.96	42.46	7.04	3.59	35.31	16.88	33.76	0.00	84.81	12.72	97.53	137.44	177.34	
IRONWORKER JOURNEYMAN - IS CONVEYOR	34.50	5.64	40.14	6.65	3.39	33.47	15.97	31.93	0.00	80.26	12.04	92.30	130.03	167.76	
MILLWRIGHT GEN. FOREMAN - IS	35.30	6.38	41.68	6.91	3.52	38.00	19.00	38.00	0.00	86.59	12.99	99.58	144.25	188.91	
MILLWRIGHT FOREMAN - IS	34.30	6.17	40.47	6.71	3.42	37.51	18.76	37.51	0.00	84.69	12.70	97.39	141.05	184.71	
MILLWRIGHT JOURNEYMAN - IS	32.30	5.82	38.12	6.32	3.22	36.86	18.43	36.68	0.00	81.30	12.20	93.50	135.39	177.09	
OPERATOR - CRANE FOREMAN - GREAT LAKES FAB	43.34	6.55	49.89	8.27	4.22	25.30	0.00	0.00	0.00	83.46	12.52	95.98	123.04	150.09	
OPERATOR - CRANE OE - GREAT LAKES FAB	41.13	6.22	47.35	7.85	4.00	25.30	0.00	0.00	0.00	80.50	12.07	92.57	118.24	143.92	
OPERATOR - FORKLIFT - GREAT LAKES FAB	39.17	5.93	45.10	7.48	3.81	25.30	0.00	0.00	0.00	77.88	11.68	89.56	114.01	138.46	

Trade	Phone #		Fax #/Email
	Local	Phone #	
Ironworkers	25	(248) 123-4567	(248) 123-4567
Millwrights	1102	(586) 756-3610	(248) 123-4567
Operators	324	(248) 451-0324	(248) 123-4567
Labors	499	(248) 123-4567	(248) 123-4567
Cement Masons	514	(248) 123-4567	(248) 123-4567
Carpenters	687	(313) 832-3887	(313) 832-8035
Labors - CD	499	(248) 334-0509	
Painter/Taper	22	(586) 552-4474	5865524477

ST. TIME	PREMIUM
FICA	7.65%
FUTA	0.80%
SUTA	2.79%
W. COMP.	2.20%
GEN. LIAB.	2.59%
INST. FL/BLD RISK	0.55%
S.B.T.	0.00%
TOTAL	16.58%
	8.45%



RFI RESPONSE TRANSMITTAL

Date: January 3, 2023

To: Frank Scheiderer

Commercial Contracting Corporation

4260 North Atlantic Blvd

Auburn Hills, MI 48326

RFI No.: 058 - Control Building AHU-1

Project Name: Delta WRRF Improvements

Project No.: 200-214200-20001

We are enclosing:

**Request
Description:**

As proposed AHU-1 has an economizer on the return duct that would move the unit approximately 49" further to the north. As per drawing MA-102 it appears there may be 12" of clearance on north side of AHU-1 making it inaccessible. The "Trane" unit submittal illustrate 60" clearance on north side of AHU-1. So, CCC is advising to give the access on the north side of wall of AHU-1 with door/gate as highlighted in the attachment. Please advise.

Response:

A double louvered gate shall be added to the west wall of the enclosure. Match east louvered gate and see attached for dimensions. Refer to approved submittal 064.B for updated powered exhaust details.

The existing foundation wall in the gate area shall be cut down 8" to install the gate posts similar to detail 1/SA304 using the gate base plate detail 2/SA304. The foundation wall shall then have the top 8" of concrete poured back with the top sloped to provide positive drainage to the outside of the enclosure.

copy:

Ernie West, P.E. (Delta Twp)

Rick Kane (Delta Twp)

Jennifer Bernardin (Delta Twp)

Tetra Tech File

By:

Jason Hunsucker

Melissa C. Hopkins, P.E.

Brent G. Bode, P.E.

Tyler Burnett, E.I.T.

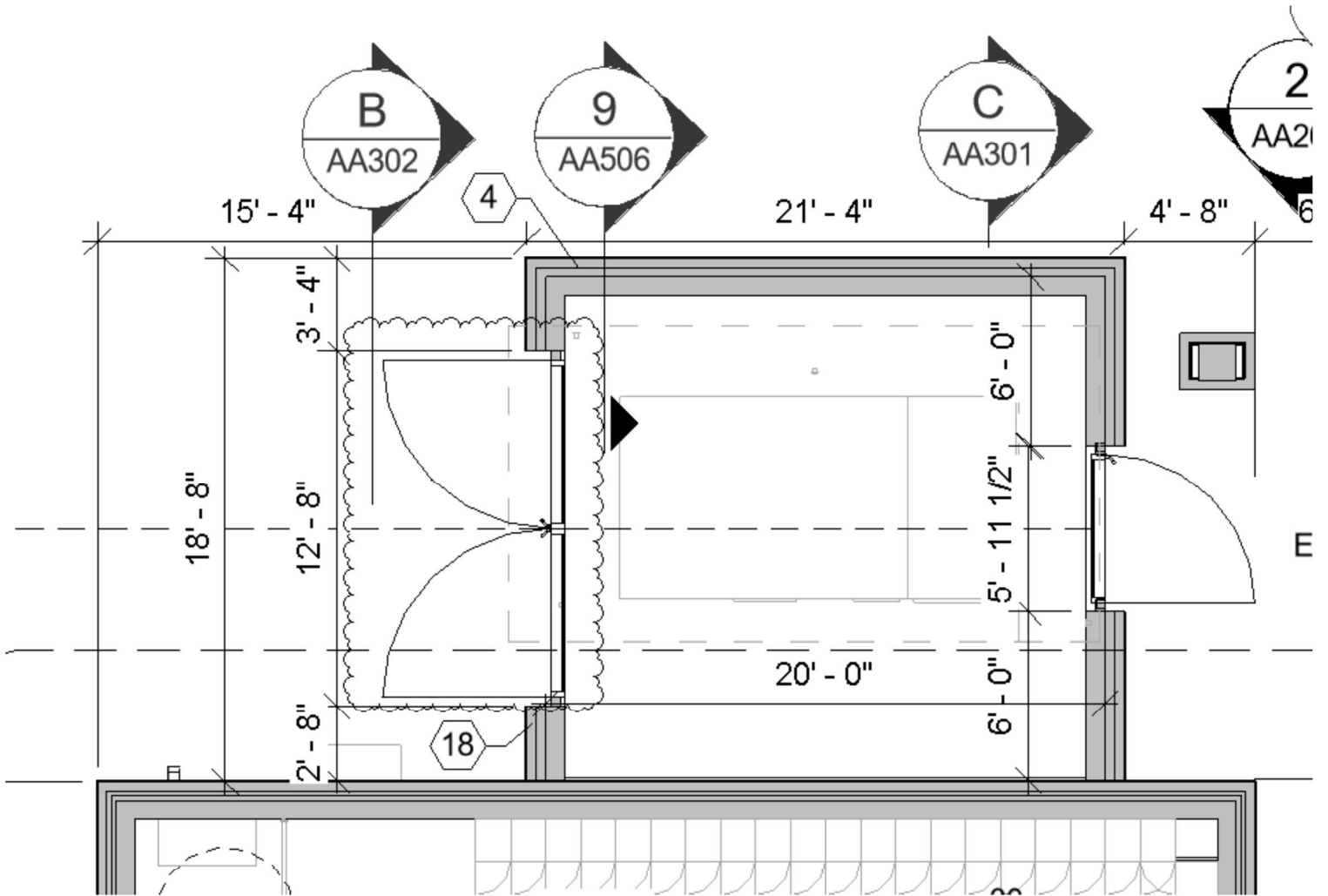



RFI #58: Control Building AHU-1

Status	Open		
To	Melissa Clough Hopkins P.E. (Tetra Tech)	From	Anuj Jayantibhai Patel (Commercial Contracting Corp) 4260 N. Atlantic Blvd. Auburn Hills, 48326
Date Initiated	Sep 22, 2022	Due Date	Sep 29, 2022
Location		Project Stage	
Cost Impact		Schedule Impact	
Spec Section		Cost Code	
Drawing Number	MA-102	Reference	
Linked Drawings			
Received From	Dan Wyman (Allied Mechanical Services)	Sub Job	
Copies To	Melissa Clough Hopkins P.E. (Tetra Tech), Mark Maloney (Commercial Contracting Corp), Alex Myers (Allied Mechanical Services), Anuj Jayantibhai Patel (Commercial Contracting Corp), Frank Scheiderer (Commercial Contracting Corp), John Taormina (Commercial Contracting Corp), Dan Wyman (Allied Mechanical Services)		

Activity

Question

Question from Anuj Jayantibhai Patel Commercial Contracting Corp on Thursday, Sep 22, 2022 at 01:49 PM EDT

As proposed AHU-1 has an economizer on the return duct that would move the unit approximately 49" further to the north. As per drawing MA-102 it appears there may be 12" of clearance on north side of AHU-1 making it inaccessible. The "Trane" unit submittal illustrate 60" clearance on north side of AHU-1. So, CCC is advising to give the access on the north side of wall of AHU-1 with door/gate as highlighted in the attachment. Please advise.

Attachments

RFI 58.pdf

Awaiting an Official Response



TETRA TECH

3497 Coolidge Road, East Lansing, MI 48823
Telephone: 517.316.3930

WORK CHANGE DIRECTIVE

DISTRIBUTION: Ernie West, P.E.
Rick Kane
Jennifer Bernardin
Tetra Tech File

TO: Frank Scheiderer
Commercial Contracting Corporation
4260 North Atlantic Blvd
Auburn Hills, MI 48326

PROJECT: DELTA TOWNSHIP
WRRF IMPROVEMENTS
PHASE I
200-214200-20001

DIRECTIVE NO.: 14

DATE: April 4, 2023

To prevent a possible delay in the work you are directed to proceed with the following changes in the work:
Furnish and install five (5) additional lockers and filler sections in the Control Building Mud Room.

Reason:

Lockers and filler sections required to fill Mud Room space allocated for lockers.

The contract amount and/or time will be adjusted by a future change order based on:

- Actual time and material costs plus OH&P
- An agreed sum to be added \$3,643.00
- An agreed sum to be deducted \$
- No change in contract price.
- No change in contract time.

A detailed breakdown is needed.
 has been received.

TETRA TECH, INC.

Recommended by: _____ Date 4/4/2023

CONTRACTOR: Commercial Contracting Corporation

Accepted by:  Frank Scheiderer Date April 11, 2023

OWNER: Delta Township

Approved by: _____ Date _____



Consider every angle®

April 3, 2023

Tetra Tech
3297 Coolidge Road
East Lansing, MI 48823

Attention: Ms. Melissa Clough Hopkins, P.E.
Environmental Engineer

Regarding: TT Contract 200-214200-20001 (CCC Job No. 3267-00)
Delta Township WRRF Major Capital Improvements Project
Adding Lockers in the Control Building (PCO 35)

Dear Ms. Hopkins,

Below is the pricing to add 5 additional lockers with fillers in the control building.

Rayhaven Group:	
Additional materials/labor =	\$3,470.00
CCC Markup @ 5% =	\$ 173.00
Total (PCO 35) =	\$3,643.00

If you have any questions, or need additional information, please let me know.

Regards,

Mark Maloney | Project Manager
COMMERCIAL CONTRACTING CORPORATION

4260 N. Atlantic Blvd. Auburn Hills, Michigan 48326
O: 248.209.0500 | C: 810.288.8563 | <https://www.cccnetwork.com>

Downtown Detroit
28 West Adams Ave. #201
Detroit, Michigan 48226



COMMERCIAL CONTRACTING CORPORATION

Corporate Headquarters
4260 North Atlantic Boulevard
Auburn Hills, Michigan 48326
248.209.0500 | www.cccnetwork.com



Steel Fabrication
4590 Joslyn Road
Lake Orion, MI 48359



Division 10

LOCKERS

CLOSET SHELVING

TOILET PARTITIONS

BATH ACCESSORIES

FIRE EXTINGUISHERS
& CABINETS

TENANT STORAGE

Stock Program

BRADLEY

Bath Accessories

- Grab Bars
- Mirrors
- Paper Holders
- Towel Bars
- Waste Receptacle
- Soap Dispensers
- Baby Changing Stations

Quotation

Metal Lockers

April 3, 2023

Attn: Mark Maloney
CCC

RE: Delta WWTP add

Description:

- 5 – 15"W x 18"D x 72"H single tier All-Welded lockers painted color 717
- 2 – 72" high locker fillers with slip joints
- 2 – Pieces of slope tops with slices

Total net delivered and installed price is	\$3,470.00
--	------------

Taxes are included in the quotation. Lead time is 8 weeks from receipt of approved shop drawings.
 Terms are Net 30 days; Quotation is good for 30 days.

Thank You,

Guenther Nieder

Supervisor Kenneth R. Fletcher
Clerk Mary R. Clark
Treasurer Dennis R. Fedewa
Manager Brian T. Reed



Trustee Elizabeth S. Bowen
Trustee Fonda J. Brewer
Trustee Andrea M. Cascarilla
Trustee Karen J. Mojica

Engineering Department

(517) 323-8540

TO: Supervisor Kenneth R. Fletcher and the Delta Township Board

FROM: Ernest A. West, P.E., Township Engineer

DATE: April 27, 2023

**SUBJECT: 2023 Concrete Sidewalk and Pathway Replacement Program
Bid Results and Recommendation for Award**

On April 20, 2023, the Township received two (2) sealed bids for the 2023 Concrete Sidewalk and Pathway Replacement Program project. This project consists of removing and replacing selected portions of deteriorated concrete sidewalk and/or pathway within Zone 3 of the Delta Township sidewalk repair program area (see attached location map).

The low bid was submitted by Bearstone Construction of Bath, Michigan, in the amount of \$106,855.00 (see attached copy of bid from Bearstone). A copy of the bid tabulation is also included with this memorandum. Note that there was a discrepancy between the calculated amount for one of the pay items and the total price indicated by the contractor for this item in their bid form. The higher amount was used by the Contractor to arrive at their total bid amount. Based on our review, this is an apparent typographical error that can be corrected when contracts are drafted without changing the total bid amount.

The Township contracted with Bearstone Construction for the 2021 Sidewalk Replacement Program project. Bearstone Construction successfully completed the previous project, and we would have no concerns about using them for this year's project. Based upon their low bid and the Township's experience with the low bidder, it is recommended that the Township Board award the contract for the subject project to Bearstone Construction for the as read bid in the amount of \$106,855.00.

The following motion is offered for your consideration:

"I move that the Delta Township Board accept the bid from Bearstone Construction for the 2023 Concrete Sidewalk and Pathway Replacement Program project in the amount of \$106,855.00. I further move that the Township Manager be authorized and directed to execute the necessary documents related to the aforementioned project."

Staff will attend the May 1, 2023 Board meeting to answer any questions or address any concerns from the Board. If there are any questions in the interim, please let us know. Thank you.

BID FORM
2023 CONCRETE SIDEWALK AND PATHWAY REPLACEMENT PROGRAM

ARTICLE 1 – BID RECIPIENT

1.01 This Bid is submitted to:

**DELTA TOWNSHIP
OFFICE OF THE TOWNSHIP CLERK
7710 WEST SAGINAW HIGHWAY
LANSING, MI 48917**

1.02 The undersigned Bidder proposes and agrees, if this Bid is accepted, to enter into an Agreement with Owner in the form included in the Bidding Documents to perform all Work as specified or indicated in the Bidding Documents for the prices and, if not specified in the Bidding Documents, within the times indicated in this Bid and in accordance with the other terms and conditions of the Bidding Documents.

ARTICLE 2 – BIDDER'S ACKNOWLEDGEMENTS

2.01 Bidder accepts all of the terms and conditions of the Instructions to Bidders, including without limitation those dealing with the disposition of Bid security. This Bid will remain subject to acceptance for 60 days after the Bid opening, or for such longer period of time that Bidder may agree to in writing upon request of Owner.

ARTICLE 3 – BIDDER'S REPRESENTATIONS

3.01 In submitting this Bid, Bidder represents that:

A. Bidder has examined and carefully studied the Bidding Documents, and any data and reference items identified in the Bidding Documents, and hereby acknowledges receipt of the following Addenda:

<u>Addendum No.</u>	<u>Addendum, Date</u>
<u>1</u>	<u>4/11/2023</u>
<u> </u>	<u> </u>
<u> </u>	<u> </u>

- B. Bidder has visited the Site, conducted a thorough, examination of the Site and adjacent areas, and become familiar with and satisfied itself as to the general, local, and Site conditions that may affect cost, progress, and performance of the Work.
- C. Bidder is familiar with and has satisfied itself as to all Laws and Regulations that may affect cost, progress, and performance of the Work.
- D. Bidder has carefully studied all: (1) reports of explorations and tests of subsurface conditions at or adjacent to the Site and all drawings of physical conditions relating to existing surface or subsurface structures at the Site, especially with respect to Technical Data in such reports and drawings, and (2) reports and drawings relating to Hazardous Environmental Conditions, if any, at or adjacent to the Site, especially with respect to Technical Data in such reports and drawings.

- E. Bidder has considered the information known to Bidder itself; information commonly known to contractors doing business in the locality of the Site; information and observations obtained from visits to the Site; the Bidding Documents; and any Site-related reports and drawings identified in the Bidding Documents, with respect to the effect of such information, observations, and documents on (1) the cost, progress, and performance of the Work; (2) the means, methods, techniques, sequences, and procedures of construction to be employed by Bidder; and (3) Bidder's safety precautions and programs.
- F. Bidder agrees that no further examinations, investigations, explorations, tests, studies, or data are necessary for the determination of this Bid for performance of the Work at the price bid and within the times required, and in accordance with the other terms and conditions of the Bidding Documents.
- G. Bidder acknowledges that this Bid and the Contract Price include the cost of correcting any error, inconsistency, or omission, which could have been discovered by the exercise of reasonable diligence. Unless Bidder establishes that such error, inconsistency, or omission could not have been discovered by the exercise of reasonable diligence, Bidder will make such corrections without additional compensation so that the Work is fully functional.
- H. Bidder is aware of the nature of work to be performed by Owner and others at the Site that relates to the Work as indicated in the Bidding Documents.
- I. Bidder has given Owner written notice of all conflicts, errors, ambiguities, or discrepancies that Bidder has discovered in the Bidding Documents and confirms that the written resolution thereof by Owner is acceptable to Bidder.
- J. The Bidding Documents are sufficient to indicate and convey understanding of all terms, conditions, and requirements for the performance and furnishing of the Work.
- K. The submission of this Bid constitutes an incontrovertible representation by Bidder that Bidder has complied with every requirement of this Article, and that without exception the Bid and all prices in the Bid are premised upon performing and furnishing the Work required by the Bidding Documents.

ARTICLE 4 – BIDDER'S CERTIFICATION

4.01 Bidder certifies that:

- A. This Bid is genuine and not made in the interest of or on behalf of any undisclosed individual or entity and is not submitted in conformity with any collusive agreement or rules of any group, association, organization, or corporation;
- B. Bidder has not directly or indirectly induced or solicited any other Bidder to submit a false or sham Bid;
- C. Bidder has not solicited or induced any individual or entity to refrain from bidding; and
- D. Bidder has not engaged in corrupt, fraudulent, collusive, or coercive practices in competing for the Contract. For the purposes of this Paragraph 4.01.D:
 - 1. "corrupt practice" means the offering, giving, receiving, or soliciting of anything of value likely to influence the action of a public official in the bidding process;
 - 2. "fraudulent practice" means an intentional misrepresentation of facts made (a) to influence the bidding process to the detriment of Owner, (b) to establish bid prices at artificial non-competitive levels, or (c) to deprive Owner of the benefits of free and open competition;

3. "collusive practice" means a scheme or arrangement between two or more Bidders, with or without the knowledge of Owner, a purpose of which is to establish bid prices at artificial, non-competitive levels; and
4. "coercive practice" means harming or threatening to harm, directly or indirectly, persons or their property to influence their participation in the bidding process or affect the execution of the Contract.

ARTICLE 5 – BASIS OF BID

Bidder will complete the Work in accordance with the Contract Documents for the following price(s):

Base Bid Unit Price Work					
Item No.	Description	Estimated Quantity	Units	Bid Unit Price	Extended Price
DIVISION A – Concrete Sidewalk Replacement					
1A	Sidewalk, Rem	541	SYD	\$ 27	\$ 14,607
2A	Sidewalk, Rem, Modified	50	SYD	\$ 27	\$ 1,350
3A	Curb and Gutter, Rem	39	LFT	\$ 18	\$ 702
4A	Curb Ramp Opening, Conc, Modified	39	LFT	\$ 30	\$ 1,170
5A	Sidewalk Ramp, Conc, 6 inch Modified	1071	SFT	\$ 8	\$ 8,568
6A	Detectable Warning Surface, Cast Iron	45	LFT	\$ 100	\$ 4,500
7A	Joint Sealant	260	LFT	\$ 2	\$ 520
8A	Mobilization	1	LSUM	\$ 3,500	\$ 3,500
9A	Sidewalk Conc, 4 inch, Sand Base	3060	SFT	\$ 7.50	\$ 22,950.00
10A	Sidewalk Conc, 4 inch, Aggregate Base	300	SFT	\$ 2.25	\$ 2,475
11A	Sidewalk Conc, 6 inch, Aggregate Base	441	SFT	\$ 9.50	\$ 4,189.50
12A	Maintaining Traffic	1	LSUM	\$ 3,000	\$ 3,000.00
Total of DIVISION A Extended Prices for Base Bid Unit Price Work (1A through 12A)					\$ 67,531.50
DIVISION B – Concrete Pathway Replacement					
1B	Mobilization	1	LSUM	\$ 3,500	\$ 3,500
2B	Sidewalk, Rem	309	SYD	\$ 27	\$ 8,343
3B	Pathway Conc, 6 inch, Modified	2779	SFT	\$ 9.50	\$ 26,400.50
4B	Joint Sealant	40	LFT	\$ 2	\$ 80
5B	Maintaining Traffic	1	LSUM	\$ 1,000	\$ 1,000
Total of DIVISION B Extended Prices for Base Bid Unit Price Work (1B through 5B)					\$ 39,323.50
Total of all Extended Prices for Base Bid Unit Price Work (1A through 5B) (subject to final adjustment based on actual quantities)				\$ 106,855.00	

Total of All Bid Items in Words: One Hundred Six Thousand Eight Hundred Fifty Five dollars

All specified cash allowances are included in the price(s) set forth above, and have been computed in accordance with Paragraph 13.02 of the General Conditions.

ARTICLE 5 – TIME OF COMPLETION

- 5.01 Bidder agrees that the Work will be substantially complete and will be completed and ready for final payment in accordance with Paragraph 15.05 of the General Conditions on or before the dates or within the number of calendar days indicated in the Agreement.
- 5.02 Bidder accepts the provisions of the Agreement as to liquidated damages.

ARTICLE 6 – ATTACHMENTS TO THIS BID

- 6.01 The following documents are submitted with and made a condition of this Bid:
 - A. Attachment A – Project References/Bidder Information;
 - B. Evidence of authority to do business in the state of the Project; or a written covenant to obtain such license within the time for acceptance of Bids;

ARTICLE 7 – DEFINED TERMS

- 7.01 The terms used in this Bid with initial capital letters have the meanings stated in the Instructions to Bidders, the General Conditions, and the Supplementary Conditions.

ARTICLE 9 – BID SUBMITTAL

This Bid submitted by: Bearstone Construction

Bidder is:

An Individual

Name (typed or printed): _____

By: _____ (SEAL)
(Individual's signature)

Doing business as: _____

A Partnership

Partnership Name: _____

By: _____ (SEAL)
(Signature of general partner – attach evidence of authority to sign)

Name (typed or printed): _____

A Corporation

Corporation Name: Bearstone Construction (SEAL)

State of Incorporation: Michigan

Type (General Business, Professional, Service, Limited Liability): LLC

By:  _____
(Signature – attach evidence of authority to sign)

Name (typed or printed): Jerry Jubb

Title: Owner
(CORPORATE SEAL)

Attest: _____

Date of Qualification to do business in Michigan is March 2018

Submittal Date: 4-20-2023

Bidder's Business Address: 4212 Drumbeller Rd
Both, MI 48808

Telephone Number: 517-908-6037

E-mail address: jerry@bearstoneconstruction.com
kelly@bearstoneconstruction.com

Bidder's License No.: _____
(where applicable)

**Attachment A
Project References/Bidder Information**

The Bidder must complete the following:

A. Active Projects

Year Begun	Owner	Contract Price	Project Description
1. 2023	City of Mason	\$98,000.00	remove/replace ^{ADA RAMP} sidewalk
2. 2023	City of Mason	\$108,000.00	New build/pavilion for Mason Public Schools
3. 2023	Martin Commercial	\$38,000.00	remove/replace loading dock
4. 2023	City of Leesburg	\$38,000.00	remove/replace sidewalk and ADA RAMP

B. Completed Similar Projects

Year Begun	Owner	Contract Price	Project Description
1. 2021	Delta Township	\$76,000	remove/replace sidewalk and ADA RAMP
2. 2019	City of Lansing	\$185,000.00	remove/replace sidewalk, curb and gutter and ADA RAMP
3. 2022	City of Pottsville	\$20,000.00	remove/replace curb gutter and ADA RAMP
4. 2022	City of Davitt	\$20,000.00	remove/replace sidewalk curb/gutter

C. Bidder's approximate bonding capacity as of January 1, 2023: One million - \$1,000,000.00

D. Name of Bidder's superintendent who will be responsible for the project

1. Jerry Jubb (Two alternate names are acceptable)

2. General Experience of Superintendent

23 years in Concrete Construction



Bid Tabulation
2023 Concrete Sidewalk and Pathway Replacement Program
Delta Township Engineering Department

Item No.	Description	Estimated Quantity	Units	Bearstone Construction Bath, MI		Able Concrete Inc. DeWitt, MI	
				Bid Unit Price	Extended Price	Bid Unit Price	Extended Price
DIVISION A - Concrete Sidewalk Replacement							
1A	Sidewalk, Rem	541	SYD	\$ 27.00	\$ 14,607.00	\$ 108.00	\$ 58,428.00
2A	Sidewalk, Rem, Modified	50	SYD	\$ 27.00	\$ 1,350.00	\$ 144.00	\$ 7,200.00
3A	Curb and Gutter, Rem	39	LFT	\$ 18.00	\$ 702.00	\$ 50.00	\$ 1,950.00
4A	Curb Ramp Opening, Conc, Modified	39	LFT	\$ 30.00	\$ 1,170.00	\$ 60.00	\$ 2,340.00
5A	Curb Ramp, Conc, 6 inch, Modified	1071	SFT	\$ 8.00	\$ 8,568.00	\$ 26.00	\$ 27,846.00
6A	Detectable Warning Surface, Cast Iron	45	LFT	\$ 100.00	\$ 4,500.00	\$ 150.00	\$ 6,750.00
7A	Joint Sealant	260	LFT	\$ 2.00	\$ 520.00	\$ 15.00	\$ 3,900.00
8A	Mobilization	1	LSUM	\$ 3,500.00	\$ 3,500.00	\$ 15,000.00	\$ 15,000.00
9A	Sidewalk Conc, 4 inch, Sand Base	3060	SFT	\$ 7.50	\$ 22,950.00	\$ 20.00	\$ 61,200.00
10A	Sidewalk Conc, 4 inch, Aggregate Base	300	SFT	\$ 2.25	\$ 675.00	\$ 22.00	\$ 6,600.00
11A	Sidewalk Conc, 6 inch, Aggregate Base	441	SFT	\$ 9.50	\$ 4,189.50	\$ 26.00	\$ 11,466.00
12A	Maintaining Traffic	1	LSUM	\$ 3,000.00	\$ 3,000.00	\$ 10,000.00	\$ 10,000.00
Total of all Extended Prices for Division A (items 1A through 12A)				\$ 65,731.50		\$ 212,680.00	
DIVISION B - Concrete Pathway Replacement							
1B	Mobilization	1	LSUM	\$ 3,500.00	\$ 3,500.00	\$ 3,000.00	\$ 3,000.00
2B	Sidewalk, Rem	309	SYD	\$ 27.00	\$ 8,343.00	\$ 108.00	\$ 33,372.00
3B	Pathway Conc, 6 inch, Modified	2779	SFT	\$ 9.50	\$ 26,400.50	\$ 24.00	\$ 66,696.00
4B	Joint Sealant	40	LFT	\$ 2.00	\$ 80.00	\$ 15.00	\$ 600.00
5B	Maintaining Traffic	1	LSUM	\$ 1,000.00	\$ 1,000.00	\$ 5,000.00	\$ 5,000.00
Total of all Extended Prices for Division B (items 1B through 5B)				\$ 39,323.50		\$ 108,668.00	
Total of all Extended Prices for Base Bid (items 1A through 5B)				\$ 105,055.00		\$ 321,348.00	

Items highlighted in yellow indicate a discrepancy from the bid form.

I certify that this is a true and correct tabulation of the bids received in Delta Township, Eaton County, State of Michigan on Thursday, April 20, 2023.

 Ernest A. West, P.E.
 Township Engineer

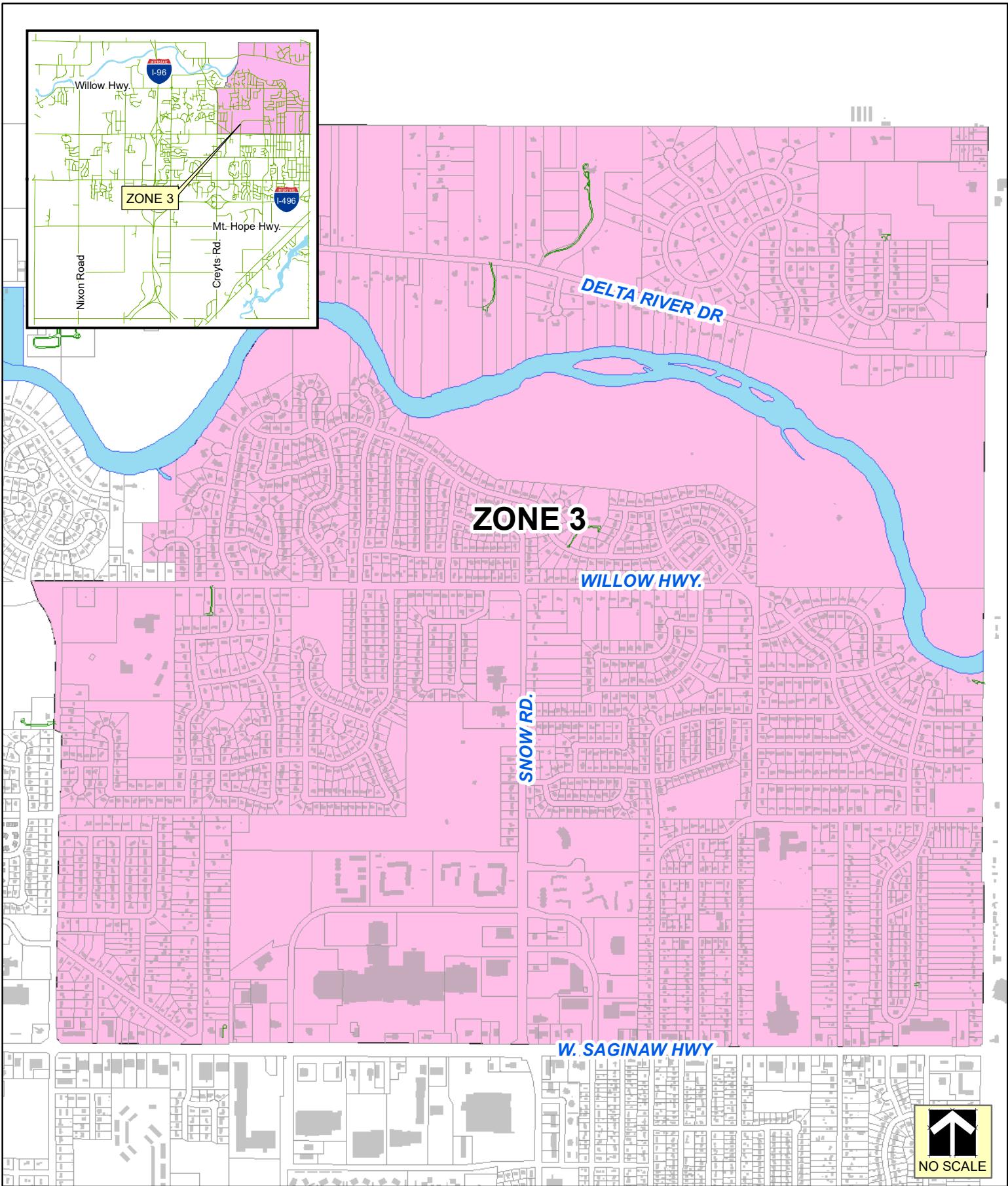

DELTA CHARTER TOWNSHIP

7710 W. SAGINAW HIGHWAY
 LANSING, MI 48917
 517.323.8555



2023
 SIDEWALK
 REPAIRS
 ZONE 3

Supervisor Kenneth R. Fletcher
Clerk Mary R. Clark
Treasurer Dennis R. Fedewa
Manager Brian T. Reed



Trustee Elizabeth S. Bowen
Trustee Fonda J. Brewer
Trustee Andrea M. Cascarilla
Trustee Karen J. Mojica

Engineering Department

(517) 323-8540

TO: Supervisor Fletcher and the Delta Township Board
FROM: Ernest A. West, P.E., Township Engineer
DATE: April 27, 2023
**SUBJECT: 2023 Concrete Sidewalk and Pathway Raising Program
Bid Results and Recommendation for Award**

On April 20, 2023, the Township received two (2) sealed bids for the 2023 Concrete Sidewalk and Pathway Raising Program project. This project consists of concrete jacking of selected portions of concrete sidewalk and/or pathway to remove trip hazards/vertical faults within Zone 3 of the Delta Township sidewalk repair program area (see attached location map).

The low bid was submitted by A-1 Concrete Leveling and Foundation Repair of Belleville, Michigan, in the amount of \$21,926.00. A copy of the bid tabulation is included with this memorandum.

The Township contracted with A-1 Concrete Leveling and Foundation Repair for the 2016 and 2020 Sidewalk Raising Program project. A-1 Concrete Leveling and Foundation Repair successfully completed each of these previous projects and we would have no concerns about using them for this years' project.

Based upon their low bid and the Township's experience with the low bidder, it is recommended that the Township Board award the contract for the subject project to A-1 Concrete Leveling and Foundation Repair in the amount of \$21,926.00.

The following motion is offered for your consideration:

"I move that the Delta Township Board accept the bid from A-1 Concrete Leveling and Foundation Repair for the 2023 Concrete Sidewalk and Pathway Raising Program project in the amount of \$21,926.00. I further move that the Township Manager be authorized and directed to execute the necessary documents related to the aforementioned project."

Staff will attend the May 1, 2023 Board meeting to answer any questions or address any concerns from the Board. If there are any questions in the interim, please let us know. Thank you.



Bid Tabulation
2023 Concrete Sidewalk and Pathway Raising Program
Delta Township Engineering Department

Item No.	Description	Estimated Quantity	Units	A-1 Concrete Leveling and Foundation Repair Belleville, MI		Concrete Raising & Leveling Company Mason, MI	
				Bid Unit Price	Extended Price	Bid Unit Price	Extended Price
DIVISION A - Concrete Sidewalk Raising							
1A	Mobilization	1	LSUM	\$ -	\$ -	\$ -	\$ -
2A	Maintaining Traffic	1	LSUM	\$ -	\$ -	\$ -	\$ -
3A	Concrete Jacking - Concrete Sidewalk	317	FLAGS	\$ 58.00	\$ 18,386.00	\$ 60.00	\$ 19,020.00
Total of all Extended Prices for Division A (items 1A through 3A)				\$	18,386.00	\$	19,020.00
DIVISION B - Concrete Pathway Raising							
1B	Mobilization	1	LSUM	\$ -	\$ -	\$ -	\$ -
2B	Maintaining Traffic	1	LSUM	\$ -	\$ -	\$ -	\$ -
3B	Concrete Jacking - Pathway 5X5	51	FLAGS	\$ 60.00	\$ 3,060.00	\$ 60.00	\$ 3,060.00
4B	Concrete Jacking - Pathway 10X10	2	FLAGS	\$ 240.00	\$ 480.00	\$ 110.00	\$ 220.00
Total of all Extended Prices for Division B (items 1B through 4B)				\$	3,540.00	\$	3,280.00
Total of all Extended Prices for Base Bid (items 1A through 4B)				\$	21,926.00	\$	22,300.00

I certify that this is a true and correct tabulation of the bids received in Delta Township, Eaton County, State of Michigan on Thursday, April 20, 2023.

 Ernest A. West, P.E.
 Township Engineer

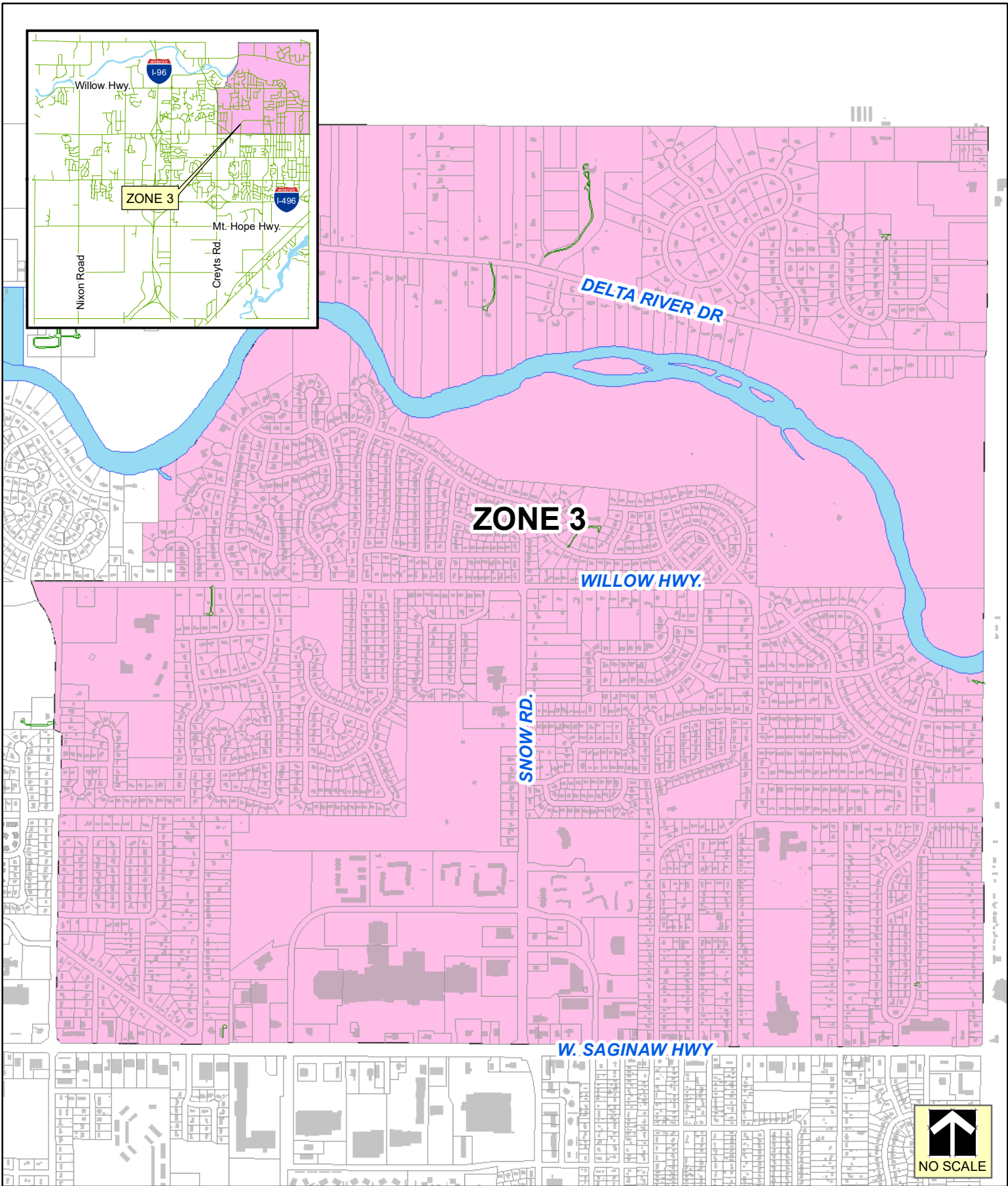

DELTA CHARTER TOWNSHIP

7710 W. SAGINAW HIGHWAY
 LANSING, MI 48917
 517.323.8555



2023
 SIDEWALK
 REPAIRS
 ZONE 3



Planning Department

(517) 323-8560

TO: Supervisor Kenneth R. Fletcher & Delta Township Board
FROM: Matt McKernan, Planner
DATE: April 26, 2023
SUBJECT: Referral of Rezoning Request for 5217 Old Lansing Rd in Case No. 03-23-07.

The Township is in receipt of an application submitted by Jeremy Hill (5205 Old Lansing Rd) to rezone the northwest 305 feet (0.86 acres) of the property located at 5217 Old Lansing Road, from O-Office to RA-Very Low Density Residential. The proposed rezoning would result in the entire 3.51 acre parcel being zoned RA-Very Low Density Residential, which would allow for the redevelopment of the former schoolhouse into a single-family home. The subject property is located in Section 35 of Delta Township.

The rezoning request is being placed on the agenda for the May 1, 2023 Regular Meeting for a referral to the Planning Commission for the purpose of holding a public hearing and making a recommendation to the Township Board. The hearing before the Planning Commission will then be scheduled for May 8, 2023.

The following motion is offered for the Board's consideration:

"I move that the Delta Township Board refer Jeremy Hill's request to rezone the property described in Case 03-23-07 from O-Office to RA-Very Low Density Residential, to the Planning Commission for the purposes of holding a public hearing on the matter and submitting a recommendation to the Township Board."

Matt McKernan, Planner
Delta Township Planning Department
517-816-8293 / mmckernan@deltami.gov





Engineering Department

(517) 323-8540

TO: Supervisor Fletcher and the Delta Township Board

**FROM: Ernest A. West, P.E., Township Engineer
Rick Kane, Utilities Director**

DATE: April 18, 2023

**SUBJECT: 2023 Municipal Water Well House Demolition
Bid Results and Recommendation for Award**

On April 4, 2023, the Township received four (4) sealed bids for the 2023 Municipal Water Well House Demolition project. The project consists of furnishing all labor, materials, and equipment for the demolition and removal of four (4) existing municipal well houses. The well pumps have been previously removed and the wells plugged in accordance with regulatory requirements. The work shall include abatement of asbestos containing materials, complete demolition, removal and disposal of masonry well house, roof structure, concrete foundations and appurtenant site features. In addition, sites shall be restored upon completion of demolition.

The Township's recent investment into making the Southern Emergency Connection to the Lansing Board of Water and Light water supply has made the remaining wells no longer necessary, which resulted in a plugging of the wells in 2022, as required by the Michigan Department of Environment, Great Lakes and Energy, to protect the groundwater aquifer.

Since the plugging of the wells in 2022, staff have begun reviewing each of the sites and well houses to determine the best use of each site in the future. Staff budgeted \$40,000 in the Water Fund in 2023 for the demolition of four (4) well houses. It is anticipated that the remaining well houses will be budgeted for demolition in 2024. The attached location map illustrates the location of the wells that are planned for demolition with this project. Staff will return to the Board at a later date with recommendations as to whether the Township should maintain ownership of the properties going forward. This will likely be a site by site determination.

The project was publicly advertised in multiple locations including the Township website, The Michigan Infrastructure & Transportation Association (MITA), and various plan rooms, such as Builder's Exchange of Lansing. The low bid was submitted by Handy Excavating, LLC, of Quincy, Michigan, in the amount of \$46,000.00. A copy of the bid tabulation is included with this memorandum.

A post bid interview was conducted with Handy Excavating. All information from Handy Excavating was found to be favorable by Staff, including our contact with references at the cities of Battle Creek and Jackson, where this company routinely completes structure demolition projects. Staff believe that Handy Excavating is qualified to complete the work and based on their low bid, it is recommended that the Township Board award the contract for the subject project to Handy Excavating in the amount of \$46,000.00. While the project is approximately 15% over the budgeted amount, the Water Fund has sufficient reserves to complete the project.



The following motion is offered for your consideration:

"I move that the Township Board accept the bid from Handy Excavating, LLC for the 2023 Municipal Water Well House Demolition project in the amount of \$46,000.00. I further move that the Township Manager be authorized and directed to execute the necessary documents related to the aforementioned project."

Staff will attend the May 1, 2023 Board meeting to answer any questions or address any concerns from the Board. If there are any questions in the interim, please let us know. Thank you.



Bid Tabulation
2023 Municipal Water Well House Demolition
Delta Township Engineering Department

Item No.	Description	Handy Excavating	ET MacKenzie	Asbestos Abatement, Inc. (AAI)	TL Contracting
		Quincy, MI	Grand Ledge, MI	Lansing, MI	Lansing, MI
		Lump Sum Bid	Lump Sum Bid	Lump Sum Bid	Lump Sum Bid
1	Well House 5 Complete Demolition and Restoration	\$ 13,500.00	\$ 17,695.00	\$ 18,795.00	\$ 30,568.00
2	Well House 9 Complete Demolition and Restoration	\$ 13,000.00	\$ 12,430.00	\$ 15,415.00	\$ 29,116.00
3	Well House 11 Complete Demolition and Restoration	\$ 10,000.00	\$ 7,643.00	\$ 18,910.00	\$ 17,945.00
4	Well House 12 Complete Demolition and Restoration	\$ 9,500.00	\$ 11,548.00	\$ 15,080.00	\$ 20,541.00
Total of all Extended Prices for Base Bid (items 1 through 4)		\$ 46,000.00	\$ 49,316.00	\$ 68,200.00	\$ 98,170.00

I certify that this is a true and correct tabulation of the bids received in Delta Township, Eaton County, State of Michigan on Tuesday, April 4, 2023.

Ernest A. West, P.E.
 Township Engineer

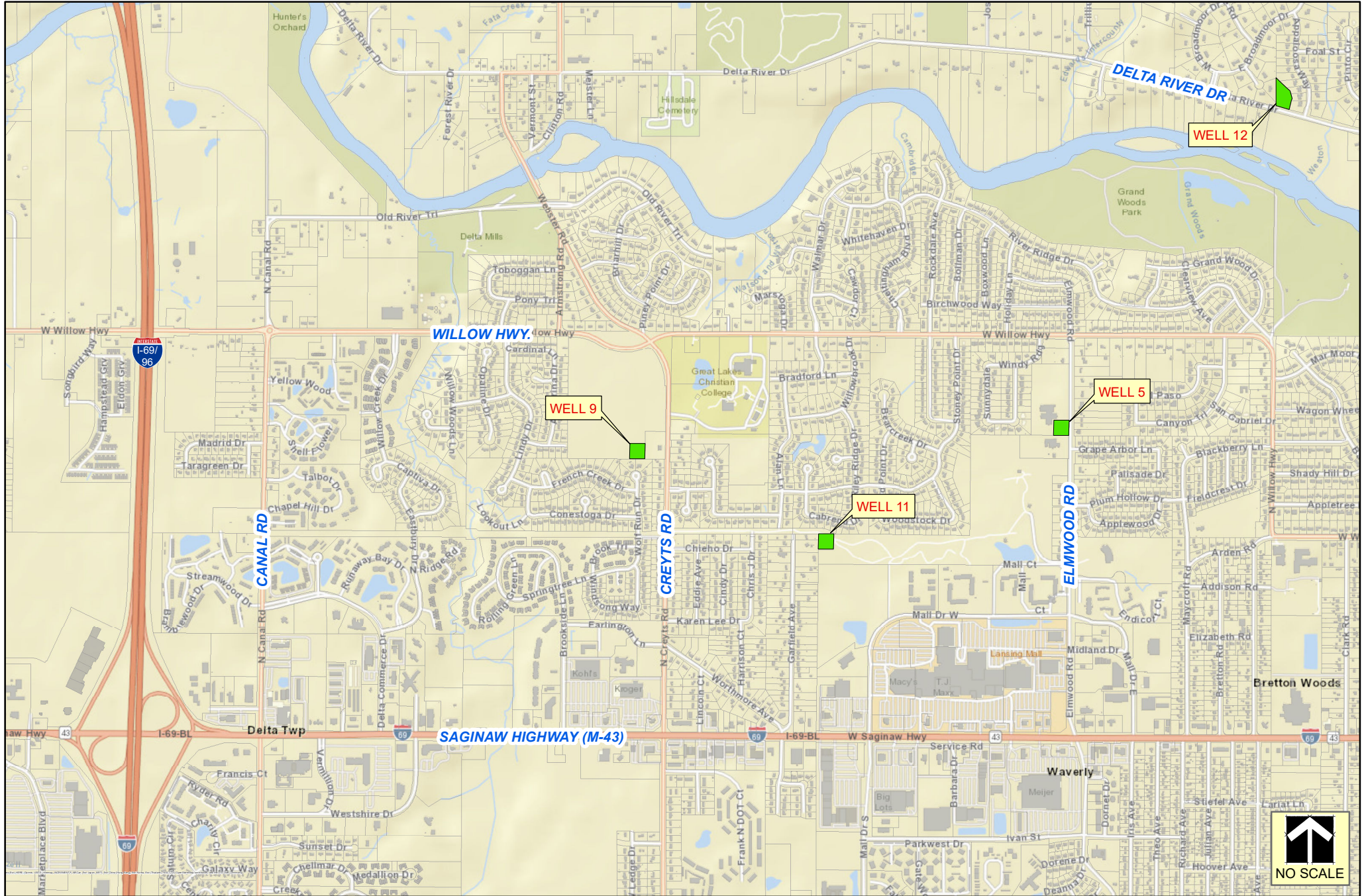

DELTA CHARTER TOWNSHIP

7710 W. SAGINAW HIGHWAY
 LANSING, MI 48917
 517.323.8555

**MUNICIPAL WATER WELL HOUSE DEMO
 LOCATION MAP 2023**





TO: Supervisor Fletcher and the Delta Township Board

FROM: Marcus Kirkpatrick, Parks, Recreation & Cemeteries Director

DATE: April 27, 2023

SUBJECT: Long-term Pool Lease Extension – Waverly Community School District

Chronology

1977 - Waverly Athletics Community Activities (WACA) began community programming which included The Delta 39ers, recreation programs and leagues, and aquatics. Delta Township began providing financial support. Over the coming years, these programs would also be supported by Lansing Township.

2003 - Delta Township took over WACA programming. Waverly Community Schools, Lansing Township, and Delta Township agreed to a partnership that would fund and operate programs.

2006 – Lansing Township announces that it would decrease its financial commitment.

2009 – Delta Township moved the Delta 39ers program to the Enrichment Center on Elizabeth Road. The new Delta Township District Library was constructed which provided an available facility for classes and programs. Delta Township also agrees to a pool lease agreement of 3 years, which allows aquatics programs to continue at Waverly East. The annual cost was \$27,000 and lasted until 2015.

2015 – Delta Township agrees to an addendum to the pool lease that would increase the annual amount to \$40,000 (2015-2016 school year), \$45,000 (2016-2017), and \$50,000 (2017-2018). These new annual costs were developed by Waverly Community Schools to meet the actual overhead cost of the pool.

2021 - The Waverly Community Schools Board of Education placed a successful 30-year, \$125 million bond proposal on the May 4, 2021, election ballot. The purpose of the bond issue was to add capacity at the elementary schools and address safety, security, and facility improvements district wide. The bond included Community locker room renovation at East Intermediate for the pool operated by Delta Township. Parks staff joined Waverly Community Schools' design team and began schematic planning.

2022 – In September, pool operations closed as construction on the locker rooms began.

2023 – In March, a grand reopening of the new renovated locker rooms and pool improvements was held, and the pool reopened at the end of the month.

Delta Township has a rich history of operating the aquatics program at Waverly East Middle School. For over 15 years, hundreds of thousands of Delta Township and Lansing area residents have benefitted from the multitude of aquatics programs that have been offered. Hundreds of children each year participate in learn-to-swim classes and take those skills with them for the rest of their lives. Delta Township Parks & Recreation is still one of the only entities in the Greater Lansing area that offers Arthritic Aqua Exercise classes with high enough water temperatures required for those classes. The collaborative partnership that has continued between Delta Township and the Waverly Community Schools has enriched the lives of so many families throughout the years. Now that the facilities have been renovated and upgraded, Delta Township will continue to maintain successful programs.

In addition to the new renovations and upgrades to the locker rooms and pool deck, Waverly Community School District (WCSD) has made past upgrades and improvements to the pool mechanical systems. Throughout the planning for the locker room project, WCSD indicated the need for a long-term lease agreement with the Township in response to the investment into the locker rooms. Township staff has met with WCSD to review the pool operations and discuss future lease terms.

The new addendum proposed by WCSD represents a very fair addendum to extend the agreement. The Township shall pay WCSD an annual payment for each fiscal year during the term for supplies, maintenance, and utilities (“Operational Costs”). In Fiscal Years 2022-2024, Delta Township will pay the amount of \$51,500 to the WCSD per fiscal year for fiscal years 2022, 2023, and 2024, consistent with past agreements. In 2025, WCSD’s Superintendent or designee may decide to monitor Operational Cost data, such as utilities, because of the project’s completion. If after reviewing that data, the Superintendent or designee determines that the payment for fiscal year 2025 should be an amount other than \$51,500, the Superintendent or designee shall contact the Township Manager by June 30, 2024, to request a meeting with the Delta Township about the annual payment amount for fiscal year 2025. WCSD and Delta Township will engage in good faith discussion to determine the annual payment for fiscal year 2025. For 2026 and beyond, annual payments shall be 3% greater than the annual payment for the immediately preceding fiscal year, beginning with an annual payment 3% above the Base Rate for 2026.

Our recommendation is to approve the addendum to pool lease with the Waverly Community School District.

I offer the following motion:

“I move that the Delta Township Board approve the Addendum to the Swimming Pool Agreement with the Waverly Community School District. I further move that the Township Board authorizes the Township Manager to sign the agreement.”

AMENDMENT TO SWIMMING POOL AGREEMENT

This Amendment to Swimming Pool Agreement (“Amendment”) is made and entered into as of the date of the last signature below (“Effective Date”) by and between Waverly Community Schools, a Michigan general powers school district operating under the provisions of the Revised School Code, MCL 380.1, *et seq.*, as amended, whose address is 515 Snow Road, Lansing, Michigan 48917 (the “District”) and Delta Charter Township, a Michigan municipal corporation, organized and operating under the Charter Township Act, MCL 42.1, *et seq.*, whose address is 7710 W. Saginaw Highway, Lansing, Michigan 48917 (the “Township”) (individually, “Party” and collectively, “Parties”).

WHEREAS:

- ... The Parties entered into a Swimming Pool Agreement effective July 1, 2009 (“Agreement”), pursuant to which the Township uses a District pool located at Waverly East Intermediate, 3131 West Michigan Avenue, Lansing, Michigan, 48917 (“Property”) for a community swimming program.
- ... The Parties entered into a series of amendments to the Agreement, specifically a Swimming Pool Compensation Addendum signed on March 16, 2010; an Addendum to the Swimming Pool Agreement effective October 1, 2015; and an Addendum to Swimming Pool Agreement effective October 1, 2019 (collectively, the “Prior Amendments”).
- ... The District pursued a bond election and project to improve the Property, and completed construction on the substantial capital improvements in March 2023 (“Project”).
- ... The District and Township desire to amend the Agreement as specified below.

NOW THEREFORE, for and in consideration of the covenants and agreements herein contained and other good and valuable consideration, the receipt and sufficiency of which are acknowledged, the Parties agree as follows:

1. **Compensation.** Section 5 of the Agreement, as originally drafted and as amended by any Prior Amendment, is hereby deleted in its entirety and replaced with the following:
 - a. For purposes of this Section, a fiscal year means a period from October 1 of a calendar year to September 30 of the immediately following calendar year. For example, fiscal year 2023 is the period from October 1, 2022 to September 30, 2023.
 - b. Annual Payments. The Township shall pay the District an annual payment for each fiscal year during the term for supplies, maintenance, and utilities (“Operational Costs”) as follows:

- i. Fiscal Years 2023-2024. The Township shall pay the amount of \$51,500 to the District per fiscal year for fiscal years 2023, and 2024. The Township shall pay the District that amount by December 1 of each such fiscal year. For example, the Township shall pay \$51,500 to the District for fiscal year 2024 by December 1, 2023.
 - ii. Fiscal Year 2025. The Superintendent or designee may monitor Operational Cost data with Project completion. If after reviewing that data the Superintendent or designee determines that the payment for fiscal year 2025 should be an amount other than \$51,500, the Superintendent or designee shall contact the Township Manager by June 30, 2024 to request a meeting with the Township about the annual payment amount for fiscal year 2025. Each Party shall work with the other Party to schedule a meeting as soon as possible following that contact. During that meeting, each Party shall engage in good faith discussion to determine the annual payment for fiscal year 2025. If the Parties agree in writing to an annual payment for fiscal year 2025 at the meeting or within 60 calendar days after that meeting, that agreed-upon amount shall be the “Base Rate” for purposes of this Agreement. Absent such agreement, the “Base Rate” shall be \$51,500 for purposes of this Agreement. The Township shall pay the Base Rate to the District for fiscal year 2025 by December 1, 2024.
 - iii. Fiscal Year 2026 and Beyond. For fiscal year 2026 and each subsequent fiscal year, the annual payment for each fiscal year shall be 3% greater than the annual payment for the immediately preceding fiscal year, beginning with an annual payment 3% above the Base Rate for fiscal year 2026. The Township shall make the annual payment to the District for each such fiscal year by December 1 of that fiscal year. For example, the Township shall pay the annual payment for fiscal year 2026 by December 1, 2025.
- c. District Pool Shutdowns. Notwithstanding anything to the contrary in this Agreement, the District has the right to close the pool (A) for regular maintenance, (B) for construction related to the Project, (C) if it reasonably determines that pool closure is required by law, or (D) if it reasonably determines that pool closure is necessary for health and safety. For pool closures pursuant to (A) or (B), the District shall provide the Township with written notice of estimated pool closure dates at least two weeks before the start of the pool closure. For pool closures pursuant to (C) and (D), the District shall provide the Township with written notice of estimated pool closure dates as soon as reasonably

possible. If the District closes the pool pursuant to this Section 5(c) and the Township was planning to use the pool during any day within the closure period, the Township may send written notice to the District identifying the dates on which the Township was planning to use the pool.

- d. Township Pool Non-Use. The Township may discontinue using the pool if it reasonably determines that use of the pool for its intended purposes is prohibited by law or if it reasonably determines that its use of the pool threatens health and safety. The Township may send the District a written notice of estimated pool non-use days.
- e. Annual Payment Proration. After the District receives a written notice from the Township under Section 5(c) or 5(d) and after the District receives the Township's annual payment for each fiscal year impacted by the pool closure or non-use, the District shall prorate the annual payment(s) and reimburse the Township for any closure or non-use days as soon as reasonably possible. For example, the reimbursement amount for a 5 day closure during fiscal year 2022 would be calculated as follows: divide the annual payment by 365 and multiply the resulting quotient by the number of closure days.

2. **Term.** Section 9 of the Agreement, as originally drafted and as amended by any Prior Amendment, is hereby deleted in its entirety and replaced with the following:

The Agreement shall be effective from October 1, 2022 through September 30, 2032 ("Initial Term"). Thereafter, the Agreement shall continue to be effective for successive one-year terms (the Initial Term and each successive one-year term, a "Term"). A Party may terminate this Agreement by sending a written termination notice to the other Party by certified mail at least 120 days before the expiration of the then-current Term, which termination shall be effective at the end of the then-current Term.

3. **Snow Removal.** Agreement Paragraph 6(b) currently states: "The Township shall pay the cost of any snow removal for all vacation days, holidays, weekends, and other like periods of the calendar year when there are no scheduled school sessions." That sentence is hereby deleted and replaced with the following: "The Township shall remove snow as it determines necessary and at its own cost on all vacation days, holidays, weekends, and other like periods of the calendar year when there are no scheduled school sessions."
4. **Ratification of Agreement.** Except as amended hereby, the Agreement shall remain in full force and effect in accordance with its terms and is hereby ratified. In the event of a conflict between the Agreement and this Amendment, this Amendment shall control.

5. **Entire Agreement.** This Amendment, together with the Agreement, contains all of the agreements of the Parties with respect to any matter covered or mentioned in this Amendment or the Agreement, and no prior agreement, understanding, or representation pertaining to any such matter shall be effective for any purpose.
6. **No Construction Against Drafting Party.** This Amendment shall not be more strictly construed against, nor shall any ambiguities within this Amendment be resolved against, a Party because that Party's participation in the drafting of this Amendment.
7. **Governing Law.** This Amendment shall be construed in accordance with and governed by the laws of the State of Michigan.
8. **Successors and Assigns.** The terms and provisions hereof shall be binding upon and inure to the benefit of the Parties hereto and their respective successors and assigns.
9. **Counterpart Signatures.** This Amendment may be executed in one or more counterparts, which shall be construed together as one document. Any signature to this Amendment that is transmitted electronically or by facsimile or by portable document format (PDF), when so executed and delivered, shall be deemed to be an original signature for all purposes.
10. **Authorization.** The person signing this Amendment on behalf of that person's respective party, as identified below, represents that person has the authority to execute this Amendment on behalf of the respective party.

DISTRICT:

**WAVERLY COMMUNITY SCHOOLS,
a Michigan general powers school district**

Signature: _____

Printed Name: Kelly Blake, Superintendent

Date: _____, 2023

TOWNSHIP:

**DELTA TOWNSHIP, a Michigan
municipal corporation**

Signature: _____

Printed Name: Brian Reed, Manager

Date: _____, 2023

SWIMMING POOL AGREEMENT

This Agreement made and entered into effective the 1st day of July, 2009, by and between Waverly Community Schools, a Michigan general powers school district operating under the provisions of the Revised School Code, MCLA 380.1, *et seq.*, as amended, whose address is 515 Snow Road, Lansing, Michigan 48917 (the "District") and Delta Charter Township, a Michigan municipal corporation, organized and operating the Charter Township Act, MCLA 42.1, *et seq.*, as amended, whose address is 7710 W. Saginaw Highway, Lansing, Michigan 48917-9712 (the "Township") (individually, "Party" and collectively, the "Parties").

WITNESSETH:

WHEREAS, the Revised School Code, 1995 PA 289, as amended, Sec. 11a (MCLA 380.11a) (hereinafter "Revised School Code") grants general powers school districts of the State of Michigan all of the rights, powers, and duties expressly stated in the Act and the exercise of power incidental or appropriate to the performance of any function related to operation of the school district in the interests of public elementary and secondary education in the school district; and

WHEREAS, Section 11a of the Revised School Code authorizes District to enter into agreements or cooperative arrangements with other entities, public or private; and

WHEREAS, the Intergovernmental Contracts Between Municipal Corporations Act, 1951 PA 35, as amended (MCL 124.2) (hereinafter Intergovernmental Contracts Act") grants any municipal corporation, including a city or a school district, the power to join with any other municipal corporation by contract for the joint operation of any property, facility or service; which each would have the power to own, operate or perform separately; and

WHEREAS, the District owns real property commonly known as "Waverly East Intermediate" located at 3131 West Michigan Avenue in Lansing Charter Township, Ingham County, Michigan, which property includes a pool; and

WHEREAS, the Township provides a community swimming program to Township residents; and

WHEREAS, the Township is willing to provide a community swimming program at the pool; and

WHEREAS, the District desires to permit the Township to assume staffing and programming responsibilities for the pool; and

WHEREAS, the Township and the District desire to define their respective rights and obligations with respect to the swimming programs, all under terms equitable and beneficial to both the Township and the District.

NOW, THEREFORE, in consideration of the covenants and conditions hereinafter set forth, the receipt and sufficiency of which are hereby acknowledged, the Parties hereto agree as follows:

1. Recitals Are Material Terms. The foregoing recitals are true and accurate and are incorporated herein as material terms of this Agreement.
2. Periods of Exclusive Use.
 - a. The Township shall be entitled to exclusive use of the pool for community swimming purposes at all times. The periods of the Township's exclusive use shall also include any day during the regular school year. The periods of the Township's exclusive use also shall include, but not be limited to, all vacation days including summer recess and all other vacations,

holidays, weekends. The hours of exclusive use shall be between 6:00 a.m. and 10:00 p.m.

3. Coordination, Supervision and Cost of Same.

- a. The Township's Director of Parks and Recreation or his/her designee shall direct and coordinate all programs conducted at the pool during the periods of the Township's exclusive use, and shall be responsible for their scheduling in conformance with the provisions of this Agreement. The Township, at its cost, shall be responsible for all personnel related to conducting, performing and/or supervising the programs at the pool during the periods of the Township's exclusive use.

4. Responsibility for Community Swimming Program.

The Township shall be responsible for providing community swimming programs. The Township shall provide such staffing as is necessary to achieve the level of programming required. The Township shall provide custodial staff for cleaning the pool, deck, locker rooms, and shower.

5. Compensation.

- a. In consideration of the obligations to be undertaken by the Township under this Agreement, the Township shall pay to the District the costs for supplies, maintenance, and utilities in the amount of \$27,000 for the period of July 1, 2009 to June 30, 2010. Payment shall be made by September 30, 2009. For the period July 1, 2010 to June 30, 2011 and thereafter, the Parties will agree at least one hundred fifty (150) days prior to the anniversary of the commencement date and agree, in writing, on the

compensation to be paid for the upcoming one (1) year period. If the Parties cannot mutually agree on the compensation to be paid, either Party may terminate this Agreement in accordance with Paragraph 9, below.

6. Responsibility for Maintenance and Repairs: Utilities; Invoicing.

- a. Except as otherwise expressly provided by this Agreement, the Township shall pay for all routine maintenance and repairs to the pool, including supplies and utilities. The Township shall reimburse the District for any custodial support or other services that the Township requests if the Township is unable to provide its own custodial staff.
- b. The District shall keep the exterior of the building, parking lot and walks in proper maintenance and repair. The District, at its cost, shall keep all sidewalks and parking in the parking lot clear of snow and ice during days of scheduled school sessions. The Township shall pay the cost of any snow removal for all vacation days, holidays, weekends, and other like periods of the calendar year when there are no scheduled school sessions.
- c. It is the intention of the Parties to this Agreement that the pool be, and remain in a condition suitable and safe for all persons using it. Accordingly, anything in this Agreement to the contrary notwithstanding, when either Party of this Agreement receives knowledge of, or otherwise becomes aware of, any defect in or damages to the center, or discovers that a portion of the pool requires repair or maintenance or otherwise poses a risk of injury to persons utilizing the pool, such Party shall immediately give the other Party written notice of such fact, including a

reasonable statement of particulars, so the appropriate repairs and/or maintenance can be performed.

d. All invoices submitted by the District to the Township under this Agreement shall be paid by the Township within thirty (30) days from receipt of same.

7. Cooperation.

Both Township and District shall jointly cooperate to do all things reasonably necessary to effectuate the purposes of this Agreement. Agents of each shall meet not less than annually to discuss any concerns that they may have and to establish operations procedures for the facilities.

8. Revenues.

Revenues, if any, derived from any program operated at the pool shall be the property of the Township.

9. Term and Termination.

The term of this Agreement shall commence July 1, 2009 and shall continue until terminated in accordance with this Section or amendments drafted pursuant to Section 11. Either Party may terminate this Agreement effective on any anniversary of the commencement date hereof by giving to the other Party written notice of its intention to terminate by no later than one hundred twenty (120) days prior to such anniversary date. In the event of any such early termination, the Parties shall each be liable for all amounts then due under this Agreement including, without limitation, their prorated shares of any amounts, regardless of

whether such sums have or have not yet been invoiced in accordance with Section 5 of this Agreement.

10. Insurance and Indemnification; Notice and Cooperation.

- a. During the term of this Agreement, the Township and District shall each maintain public liability and property damage insurance covering their respective activities and programs at the facilities, with coverage limits of not less than \$1,000,000 per injury and \$3,000,000 annual aggregate, and naming the other Party as an "additional insured" and not a mere certificate holder. The Township and District shall each furnish the other with evidence of such insurance on an annual basis. The Parties' insurance policies shall provide waivers of subrogation by each Party against the other, by endorsement or otherwise.
- b. To the extent permitted by law, Township shall save and hold District (including District's officers, officials, employees, agents, representatives, successors and assigns) from and against any and all claims, liability, costs (including court and litigation costs and attorney fees) and controversies of any and every kind including, without limitation, those for death, personal injury, and property damage, which arise out of and/or are due in any way, directly or indirectly, to the acts and/or omissions of Township and/or of any of Township's officers, officials, employees, agents or representatives, including, without limitation, negligent or inadequate supervision by the Township of any activity conducted by the Township on the facilities

during a period in which the Township had exclusive use of the facilities pursuant to Section 2 of this Agreement.

- c. To the extent permitted by law, District shall save and hold Township (including Township's officers, officials, employees, agents, representatives, successors and assigns) from and against any and all claims, liability, costs (including court and litigation costs and attorney fees) and controversies of any and every kind including, without limitation, those for death, personal injury, and property damage, which arise out of and/or are due in any way, directly or indirectly, to the acts and/or omissions of District and/or of any of District's officers, officials, employees, agents or representatives, including, without limitation, negligent or inadequate supervision by the District of any activity conducted by the District on the facilities during a period in which District had exclusive use of the facilities pursuant to Section 2 of this Agreement.
- d. Each Party hereto shall give written notice to the other Party of any matter pertaining to the facilities which may give rise to a claim against either Party as the result of such Party's entry into or performance of this Agreement as soon as practicable after the Party receives knowledge of the facts which may give rise to such claim.
- e. To the extent reasonably possible, taking into consideration the Parties' respective legal interests, the Parties shall fully cooperate in any defense of any claim that may be asserted against either Party.

- f. The Parties intend that their respective obligations to indemnify the other Party be equal and coextensive.

11. Miscellaneous.

- a. Benefit; No Assignment. This Agreement shall be binding upon and inure to the benefit of the Parties and their respective legal representatives, successors and assigns. Neither Party may assign any of its rights or obligations under this Agreement without the prior written consent of the other Party.
- b. Waiver. The waiver by any Party to this Agreement of any provision of this Agreement or of any breach of this Agreement shall not operate as or be construed as a continuing waiver of such provision or a waiver of any continuing breach, subsequent breach, or any other breach, and any statement or conduct by or of any Party or such Party's representative with respect to any such waiver, shall not estop such Party from asserting or exercising any rights with respect to any provision or any subsequent, continuing or other breach. No waiver shall be valid unless it is asserted in a written document and signed by the duly authorized representative of the Party against whom such waiver is being asserted.
- c. Severability. If any provision or part of this Agreement is held to be invalid or unenforceable by any court of competent jurisdiction, such determination shall not affect the remaining parts or provisions of this Agreement which shall continue in full force and effect, unless such severance would materially destroy the intent of the Parties in entering

into this Agreement, in which case the Parties shall immediately commence negotiations to achieve a revised, fully valid and enforceable Agreement; provided, however, that if such a revised, fully valid and enforceable Agreement is not executed by both Parties within sixty (60) days after the event triggering severance, then either Party may immediately terminate this Agreement by written notice to the other Party.

- d. Prior Agreements and Amendments. This Agreement embodies the entire agreement and understanding between the Parties hereto with respect to the subject matter hereof. There are not other agreements or understandings, oral or written, between the Parties hereto with respect to the subject matter hereof, and this Agreement supersedes all previous negotiations, commitments, agreements and understandings, oral and written, between the Parties hereto with respect to the subject matter hereof.
- e. Counterparts. The Parties may execute this Agreement in several counterparts, each of which shall be deemed to be an original, and all of such counterparts together shall constitute and be one and the same instrument.
- f. Modifications. This Agreement can be modified or amended only by a written document signed by each Party's chief executive officer after his/her receipt of any authorization of that Party's governing body required by law.

- g. No Rule of Construction. Both Parties and their respective counsel have read, negotiated and participated in the drafting of the language and terms used in this Agreement. Accordingly, no rule of construction shall apply to this Agreement which construes any language, whether, ambiguous, unclear or otherwise, in favor of, or against, any Party by reason of that Party's role in drafting this Agreement.
- h. Governing Law. This Agreement shall be governed by the laws of the State of Michigan.
- i. Notices. Notices to be given pursuant to this Agreement shall be in writing; be signed by an authorized representative of the Party giving same; and be given by U.S. mail, postage prepaid, or by hand-delivery, or by overnight express courier, charges prepaid. Notices shall be addressed as follows:

As to District: Waverly Community Schools
 Attn: Superintendent of Schools
 515 Snow Road
 Lansing, Michigan 48917

As to Township: Delta Charter Township
 Attn: Township Manager
 7710 W. Saginaw Highway
 Lansing, Michigan 48917-9712

ADDENDUM TO THE SWIMMING POOL AGREEMENT

Between

Waverly Community Schools (the "District")

And

Delta Charter Township (the "Township")

The purpose of this Addendum is to amend the original Swimming Pool Agreement, between the District and the Township, dated July 1, 2009. The Addendum affects only the specific items outlined below. The parties agree to the following regarding:

Section 5. Compensation:

In consideration of the obligations to be undertaken by the Township under this Agreement, the Township shall pay to the District the costs for supplies, maintenance and utilities as follows:

For fiscal year 2019-20, the amount of Fifty-One Thousand Five Hundred Dollars (\$51,500.00) for the period of October 1, 2019 through September 30, 2020.

Compensation shall be indexed annually, beginning October 1, 2020 at a rate of 3% above the immediately preceding fiscal year.

Payment shall be made by annually by December 1.

Section 9. Term and Termination

This agreement shall commence on October 1, 2019 and renew automatically on October 1 of each subsequent year, unless terminated by either party. Should either party desire not to renew this agreement at the end of the then current term, that party shall give the other party a one hundred twenty (120) day notice prior to the end of that current term.

WAVERLY COMMUNITY SCHOOLS

By: Kelly Blake
Its: Superintendent of Schools

Dated: 3-12-2020

DELTA CHARTER TOWNSHIP

By: [Signature]
Its: Township Supervisor
Manager

Dated: March 3, 2020



Engineering Department

(517) 323-8540

TO: Supervisor Kenneth R. Fletcher and the Delta Township Board

FROM: Ernest A. West, P.E., Township Engineer

DATE: April 18, 2023

**SUBJECT: 2023 Administration Building Interior Modifications
Bid Results and Recommendation for Award**

On March 23, 2023, the Township received three (3) sealed bids for the 2023 Administration Building Interior Modifications project. This project consists of interior modifications and renovations to the Delta Township Administration Building in the Manager's Office, Clerk's Office and Second Floor Conference Room. Modifications to these spaces include partial demolition, new partition walls, windows, doors and millwork, new ceiling, flooring and wall finishes, and associated mechanical, electrical and lighting.

The modifications to these spaces are required to improve functionality of the spaces, specifically:

- ... Manager's Office modifications reworks the reception area by partitioning the space to add another workstation to accommodate an additional administrative position and improve work environment by enclosing the workstations in this area to cut down on distractions from foot traffic in the space (while still providing a service window). This project does not include any renovations to the existing closed offices in the manager's office with the exception of updates and a refresh of Linda Wells previous office space to be completed during this project.
- ... Clerk's Office modifications add a second, ADA compliant service counter to increase capacity to handle walk up traffic during high volume periods. Modifications to the back storage areas will separate document storage from voting equipment storage and improve circulation within the space when voting equipment is set up for pre-election testing.
- ... Second Floor Conference Room modifications will add dedicated cooling to the conference room, which currently overheats when multiple person meetings are held. Modifications will also update room finishes, improve lighting and sound proofing of the space and add audio/visual equipment to add video display capability. This conference room also replaces the former Manager's Conference Room in the Manager's Office, which was required to be converted to office space to house Human Resources staff.

A copy of the bid tabulation is included with this memorandum. The low bid for the project was submitted by Wolverine Building Group of Grand Rapids, Michigan, in the amount of \$176,359.00. The second lowest bid was submitted by Moore Troper of Holt, Michigan in the amount of \$179,200.00. The Administrative Building Updates project is included in the 2023 budget in the amount of \$130,000. While the project is significantly over budget, the bids received were very competitive and Staff believe that they represent market conditions at this time. There is no significant scope of work that can be removed from the project to lower the project cost and still achieve the desired outcomes. Therefore, Staff are recommending that they project proceed as bid, with additional funding coming from reserves.

Staff conducted a post bid interview with both Wolverine Building Group and Moore Trosper. All information from Wolverine Building Group and Moore Trosper was found to be favorable. Both Wolverine Building Group and Moore Trosper are well-established contractors that Staff believe are capable of successfully completing the project. Based upon their low bid, Staff recommend that the Township Board award the contract for the project to Wolverine Building Group in the amount of \$176,359.00.

The following motion is offered for your consideration:

"I move that the Delta Township Board accept the bid from Wolverine Building Group for the 2023 Administration Building Interior Modifications project in the amount of \$176,359.00. I further move that the Township Manager be authorized and directed to execute the necessary documents related to the aforementioned project."

Staff will attend the May 1, 2023 Board meeting to answer any questions or address any concerns from the Board. If there are any questions in the interim, please let us know. Thank you.



Bid Tabulation

2023 Administration Building Interior Modifications

Delta Township Engineering Department

Item No.	Description	Wolverine Building Group	Moore Trosper	Professional Construction and Consultants Inc
		Grand Rapids, MI	Holt, MI	Westbloomfield, MI
		Lump Sum Bid Price	Lump Sum Bid Price	Lump Sum Bid Price
1	Manager's Office Area, Complete, Business Hours	\$ 85,181.00	\$ 81,500.00	\$ 83,350.00
2	Clerk's Office Area, Complete, Business Hours	\$ 61,267.00	\$ 63,700.00	\$ 62,810.00
3	Second Floor Conference Room, Complete, Business Hours	\$ 29,911.00	\$ 34,000.00	\$ 42,350.00
Total Lump Sum Base Bid		\$ 176,359.00	\$ 179,200.00	\$ 188,510.00

ALTERNATES

Item No.	Description	Lump Sum Bid Price	Lump Sum Bid Price	Lump Sum Bid Price
Alt 1	Manager's Office Area, Additional Cost to Complete Work After Hours or Weekends	\$ 18,611.00	\$ 100,300.00	\$ 87,350.00
Alt 2	Clerk's Office Area, Additional Cost to Complete Work After Hours or Weekends	\$ 14,659.00	\$ 78,100.00	\$ 66,810.00
Alt 3	Second Floor Conference Room, Additional Cost to Complete Work After Hours or Weekends	\$ 10,364.00	\$ 42,000.00	\$ 45,350.00

I certify that this is a true and correct tabulation of the bids received in Delta Township, Eaton County, State of Michigan on Thursday, March 23, 2023.

Items highlighted in yellow indicate a discrepancy from the bid form.

Ernest A. West, P.E.
Township Engineer

Supervisor Kenneth R. Fletcher
Clerk Mary R. Clark
Treasurer Dennis R. Fedewa
Manager Brian T. Reed



Trustee Elizabeth S. Bowen
Trustee Fonda J. Brewer
Trustee Andrea M. Cascarilla
Trustee Karen J. Mojica

Manager's Office

(517) 323-8590

To: Supervisor Kenneth R. Fletcher and the Delta Township Board

From: Brian Reed, Township Manager

Date: April 26, 2023

Subject: Private Development Update

On February 13, 2023, staff made a presentation to the Township Board regarding recent private development proposals in the Township, highlighting challenges and infrastructure restrictions that play a major role in future development and infrastructure discussions and decisions. Since that time staff and an engineering consultant have been evaluating the effects of the proposed developments on existing sanitary sewer infrastructure and identifying options for upgrading infrastructure to accommodate the developments.

On Monday, May 1, 2023, staff will present findings from these efforts. Township Engineer Ernie West, Planning Director Gary Bozek, and Utilities Director Rick Kane will all be on hand to answer questions.

The background of the slide is a large, stylized fire department logo. It features a central Maltese cross with a white center and red and blue outer sections. Inside the cross are various firefighting symbols: crossed axes at the top, a fire hydrant on the right, a blue Star of Life (EMS symbol) at the bottom, and crossed tools on the left. A central circular emblem contains a yellow triangle with a red flame, a blue base with crossed silver axes, and a yellow rope border. The words "FIRE DEPARTMENT" are written in yellow on a blue banner at the bottom. A white horizontal line is positioned below the text.

2022 Annual Report

Delta Township Fire Department Mission Statement



“The mission of the Delta Township Fire Department is to protect and enhance the quality of life through comprehensive services directed toward public education, prevention, and control in the areas of fire, rescue, medical emergencies, hazardous materials incidents, and disasters.

We commit to delivering these services with the highest standard of professionalism, integrity, and accountability.”

Contents

- Fire/EMS Division
- Fire Prevention
- Training
- Emergency Management
- Department Accomplishments
- Future Goals





Fire/EMS Division

2022 Annual Report

Fire/EMS Division - ECCCD



EMS Calls for Service

Agency	Calls	Percentage
Benton Township EMS	1,082	6.3%
Delta Township EMS	5,971	34.9%
Eaton Area EMS	6,113	35.7%
Grand Ledge EMS	2,039	11.9%
Vermontville EMS	231	1.4%
Windsor EMS	1,289	7.5%
Other Agencies	380	2.2%
Total	17,105	100%



Fire Calls for Service

Agency	Calls	Percentage
Bellevue Fire	346	3.9%
Benton Township Fire	346	3.9%
Charlotte Fire	1,116	12.4%
Delta Township Fire	3,123	34.8%
Eaton Rapids Fire	792	8.8%
Eaton Rapids Township Fire	795	8.9%
Grand Ledge Fire	696	7.7%
Hamlin Township Fire	215	2.4%
Olivet Fire	311	3.5%
Roxand Township Fire	179	2.0%
Sunfield Township Fire	300	3.3%
Vermontville Township Fire	159	1.8%
Windsor Township Fire	495	5.5%
Other Agencies	108	1.2%
Total	8,972	100%

2022 Annual Report Fire/EMS Division

2022 Calls for Service 6,720

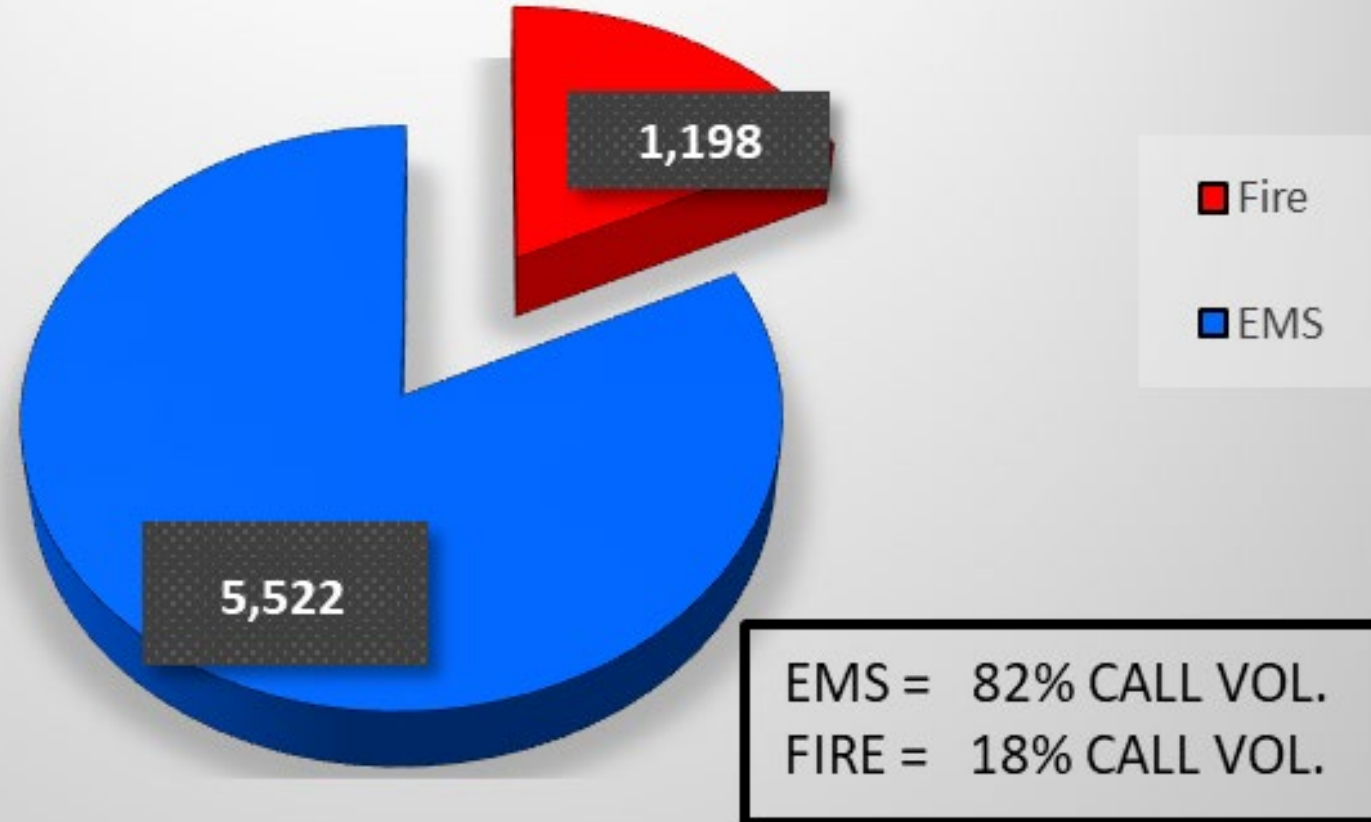

4-Year Comparison

FIRE INCIDENTS 4-YEAR TREND

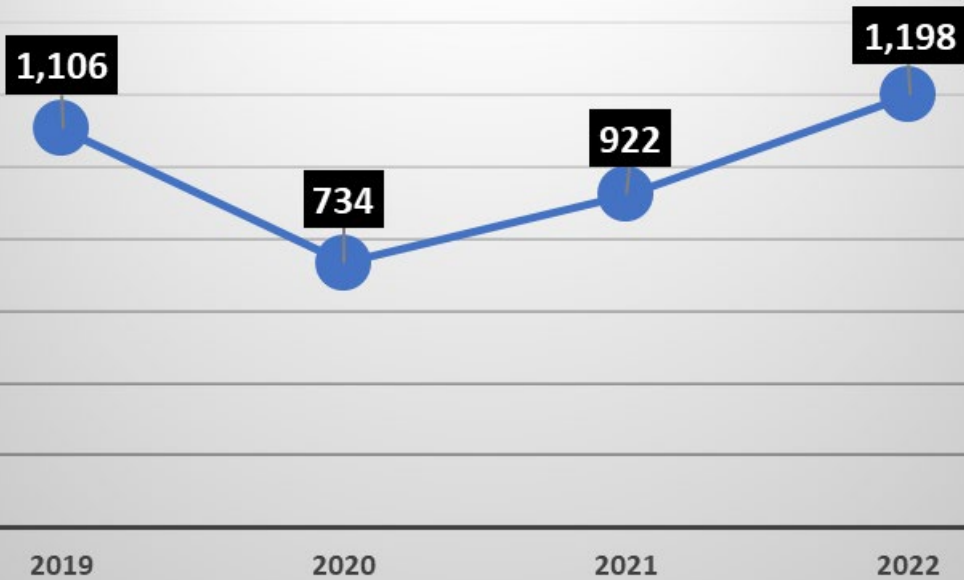

EMS INCIDENTS 4-YEAR TREND

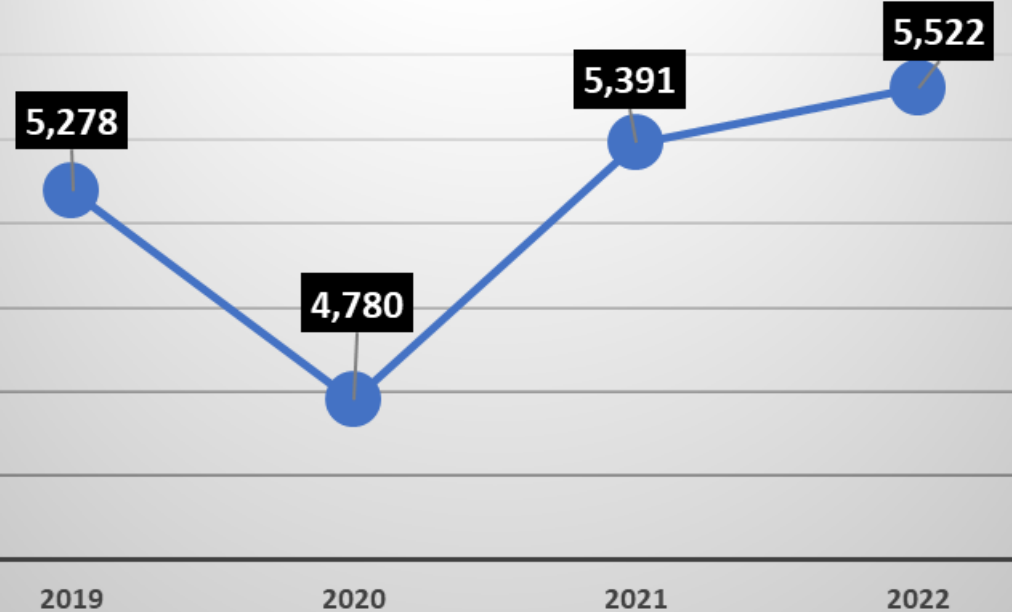

2022 Annual Report

Fire/EMS Division

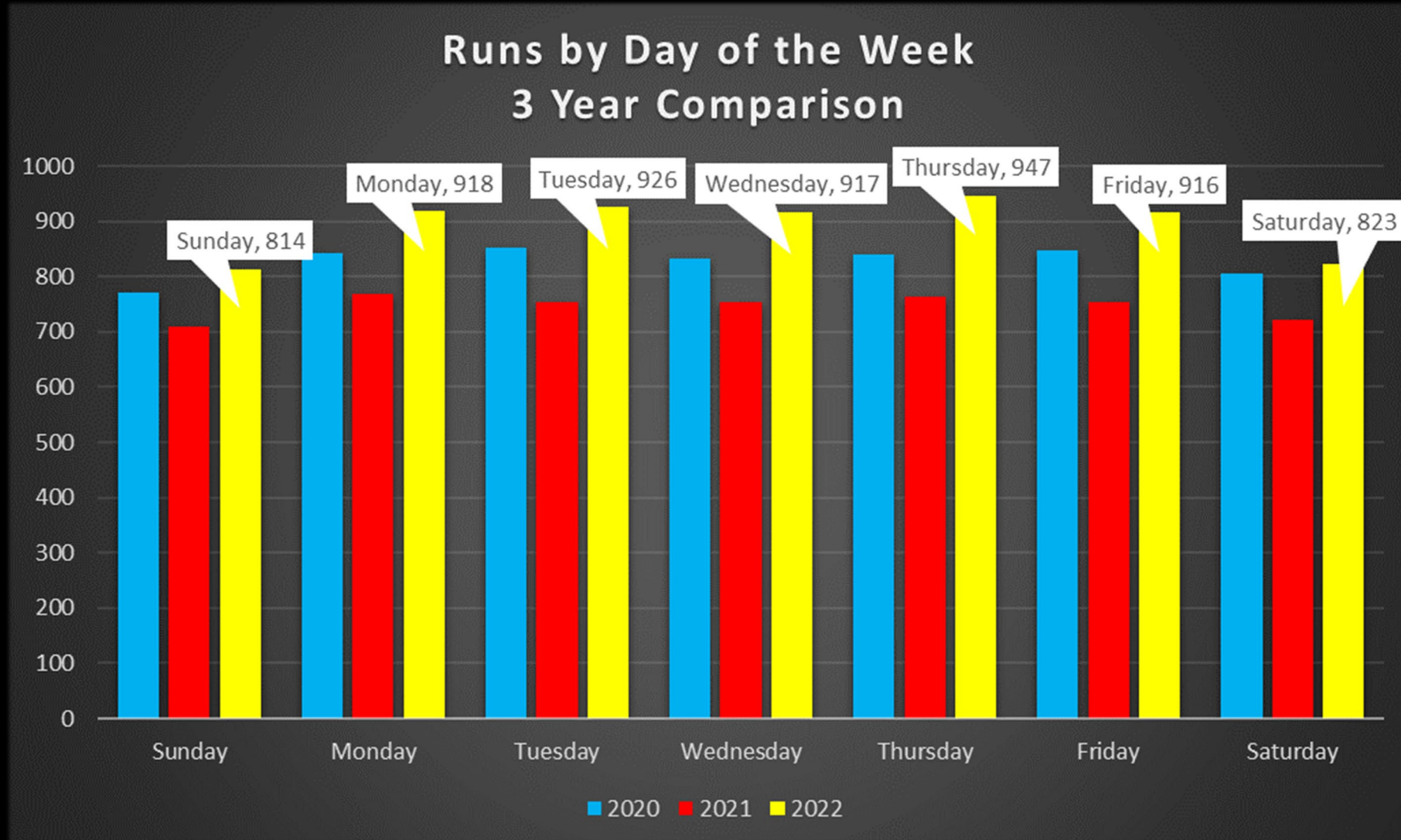

2022 Annual Report Fire/EMS Division

Calls By Hour of the Day - 3 Yr Comparison

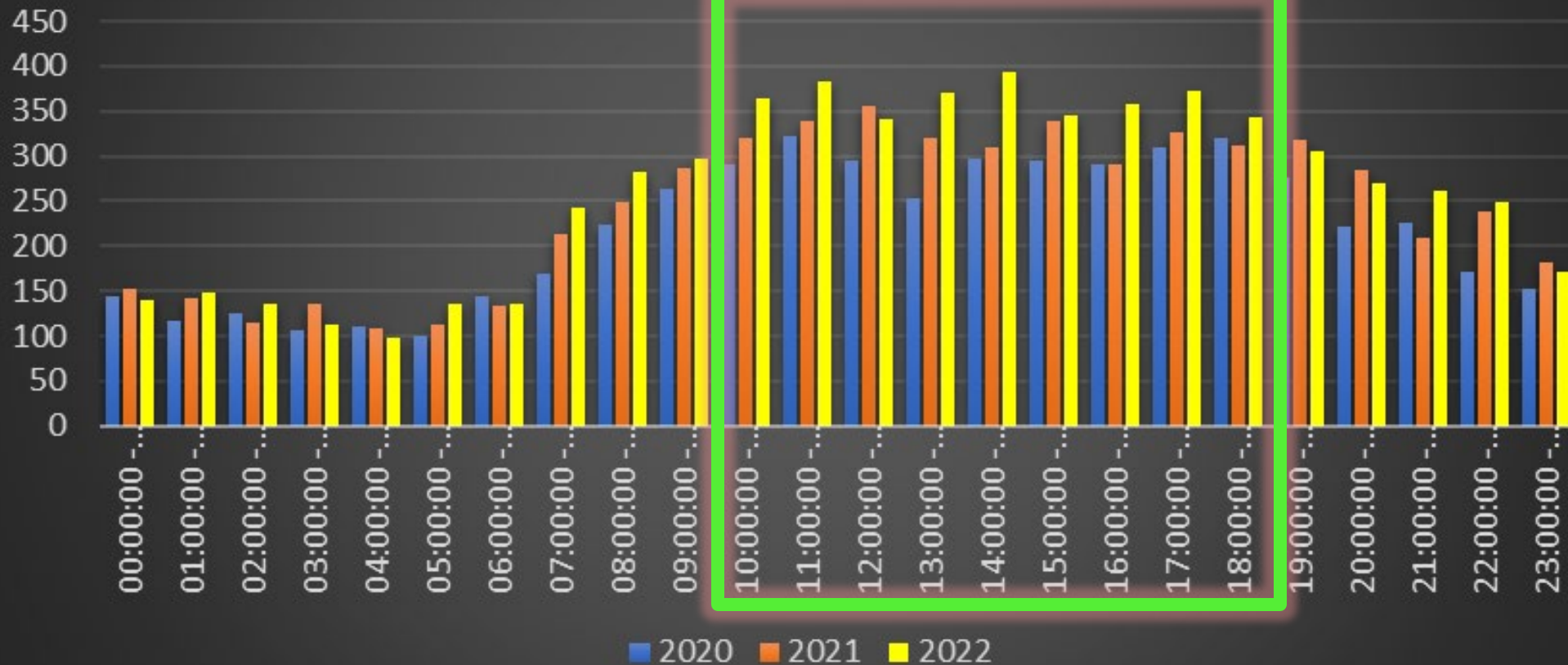

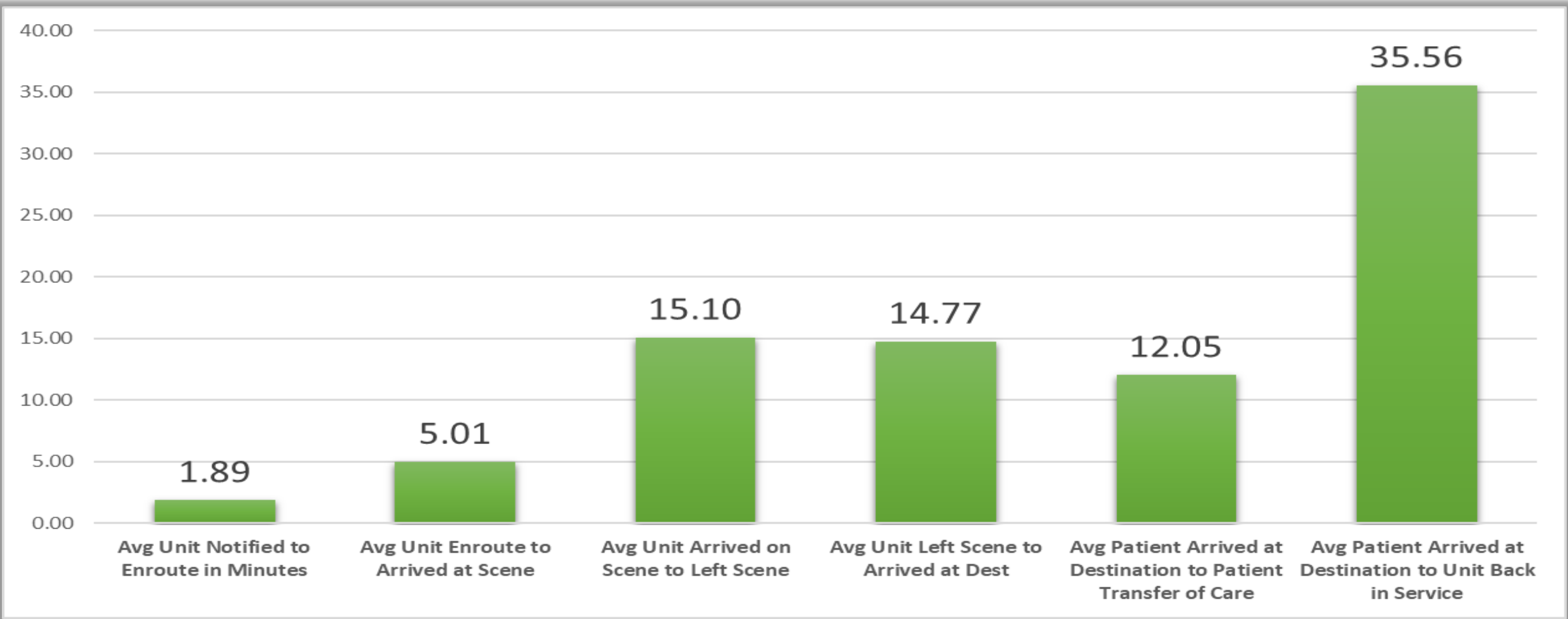

2022 Annual Report

Fire/EMS Division

PSAP to Alarm Times

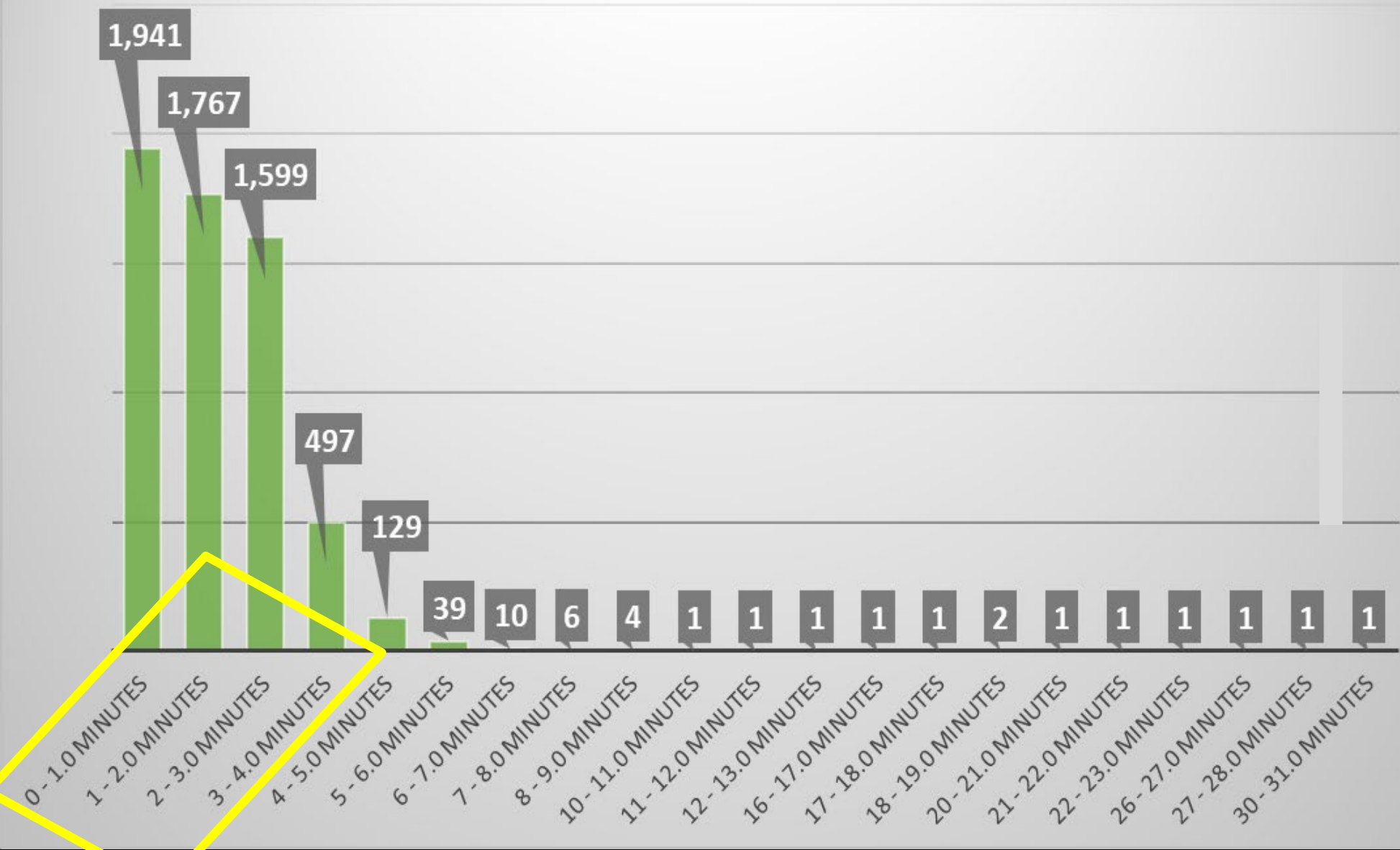

2022
Annual
Report
Fire/EMS
Division

Pt Arrival to Transfer of Care - In Minutes

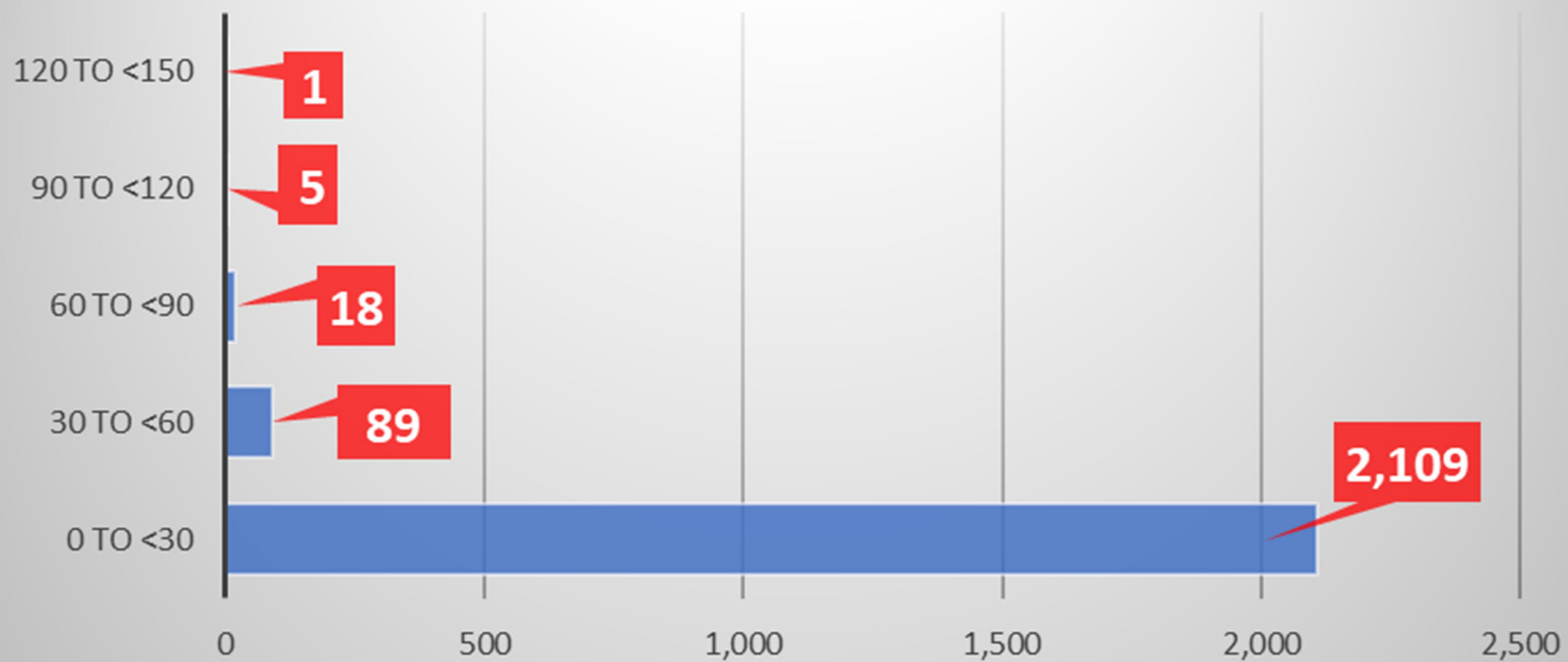

Top 15 Busiest Addresses

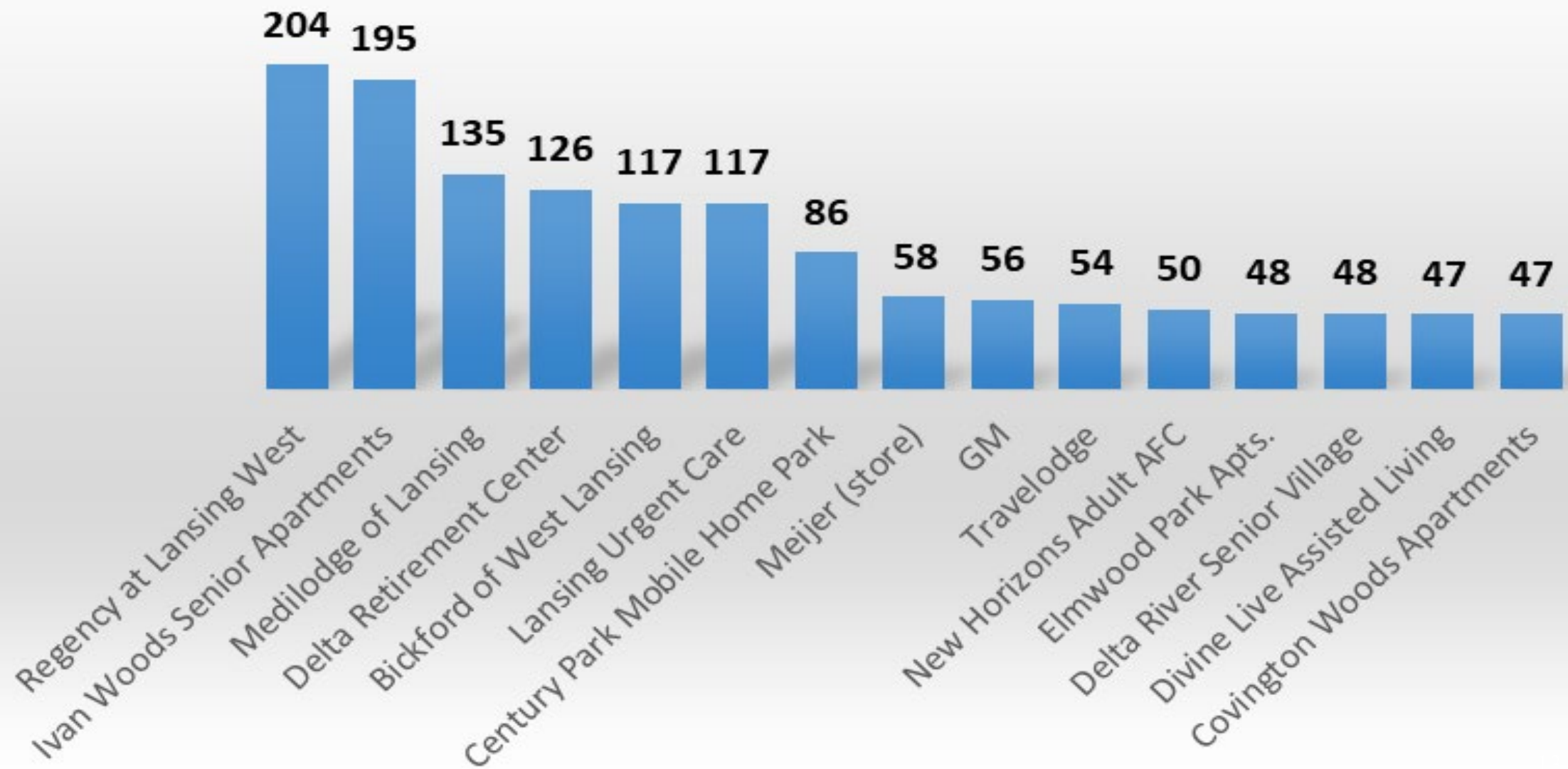

2022 Annual Report Fire/EMS Division

- **77 Basic Property Codes**

- **1-2 Family – 2, 613**
- **Multifamily – 1,124**
- **24-hr Care – 661**
- **Other – 454**
- **Highway, street – 450**
- **Ind., Utility, Ag. – 163**
- **Hotel/Motel – 160**
- **Clinics – 109**
- **Restaurants, Café – 93**
- **Residential/Board/Care – 89**
- **Vehicle Parking Area – 72**

Incidents by General Property Use

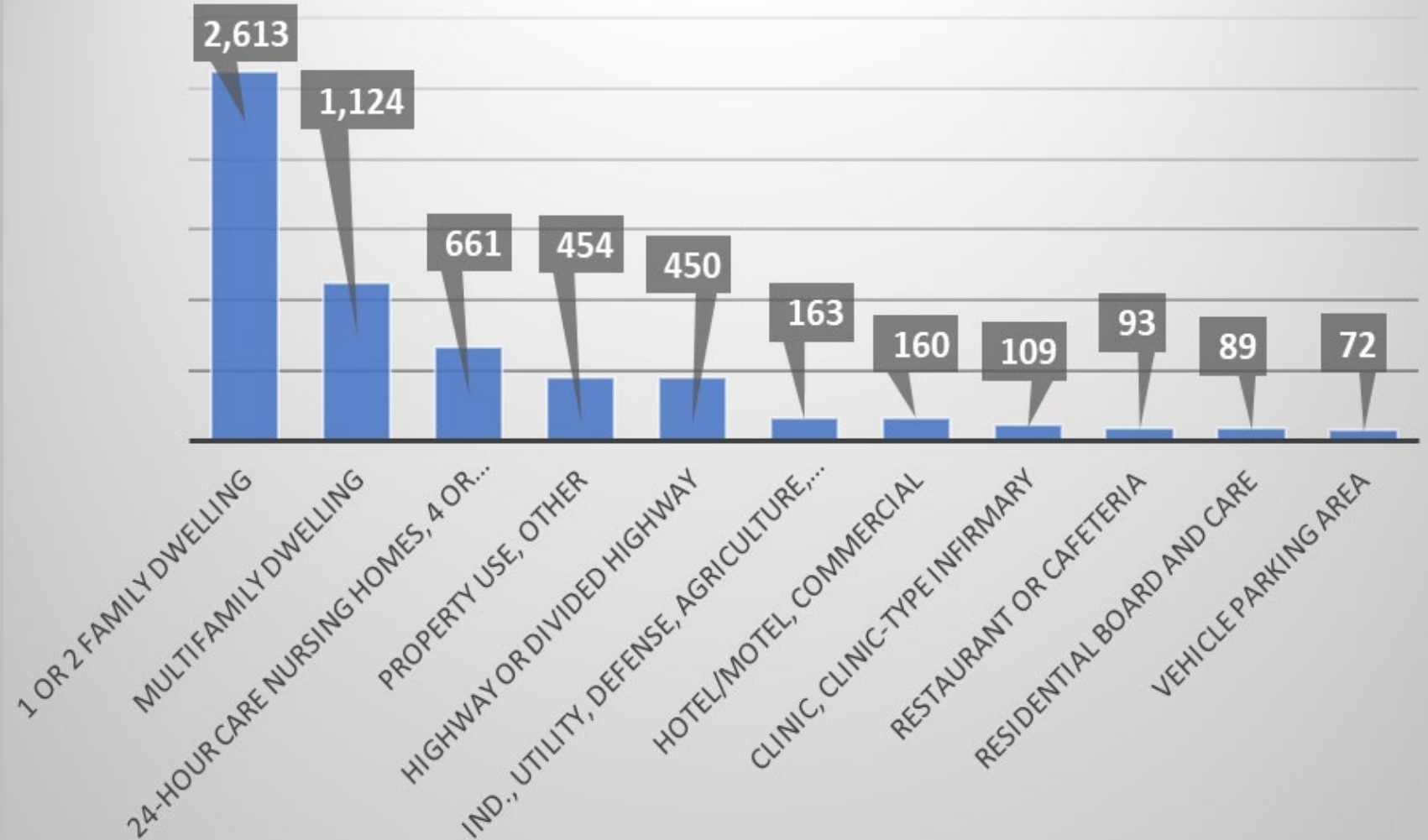

Response Mapping – Heat Maps

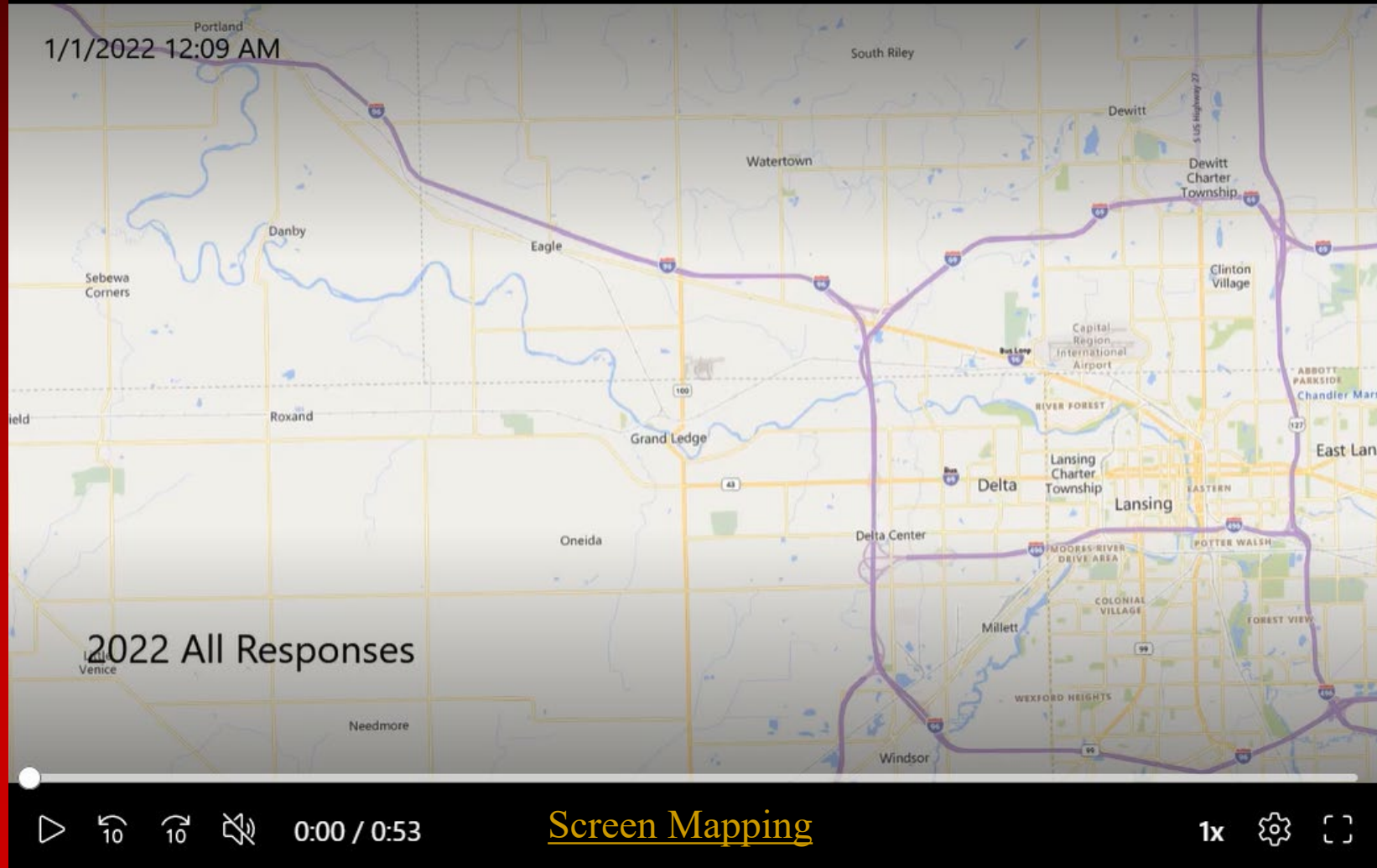

2022 Annual Report AccuMed

Account Performance

	2019	2020	2021	2022
Total Run Volume	4,954	4,522	4,417	3,997
ALS Run Volume	3,252	2,689	2,917	2,399
BLS Run Volume	937	1,079	1,026	1,415
Treat No Transport	400	506	141	114
Vehicle Accident Volume	365	248	333	69
Gross Charges	\$3,114,825.26	\$2,777,846.91	\$3,307,535.99	\$3,040,186.57
Contractuals*	\$928,860.40	\$872,137.01	\$1,217,880.25	\$1,045,836.15
Payments	\$1,690,633.40	\$1,487,749.96	\$1,564,031.71	\$1,655,857.26
Average Recovery Per Run	\$341.27	\$329.00	\$354.09	\$414.28

*Contractuals=Amounts above Federal, State and Local carriers that legally cannot be billed to secondary carriers or patients.

**Net=Charges-Contractuals=Net Charges Payments/NetCharges=Net%

Payor Mix

	2019	2020	2021	2022
Medicare	47%	46%	43%	49%
Medicaid	15%	16%	16%	17%
Commercial	29%	27%	29%	25%
Self Pay	9%	11%	12%	9%

Community Risk Reduction

Fire Prevention Division



Fire is
Everyone's
Fight™

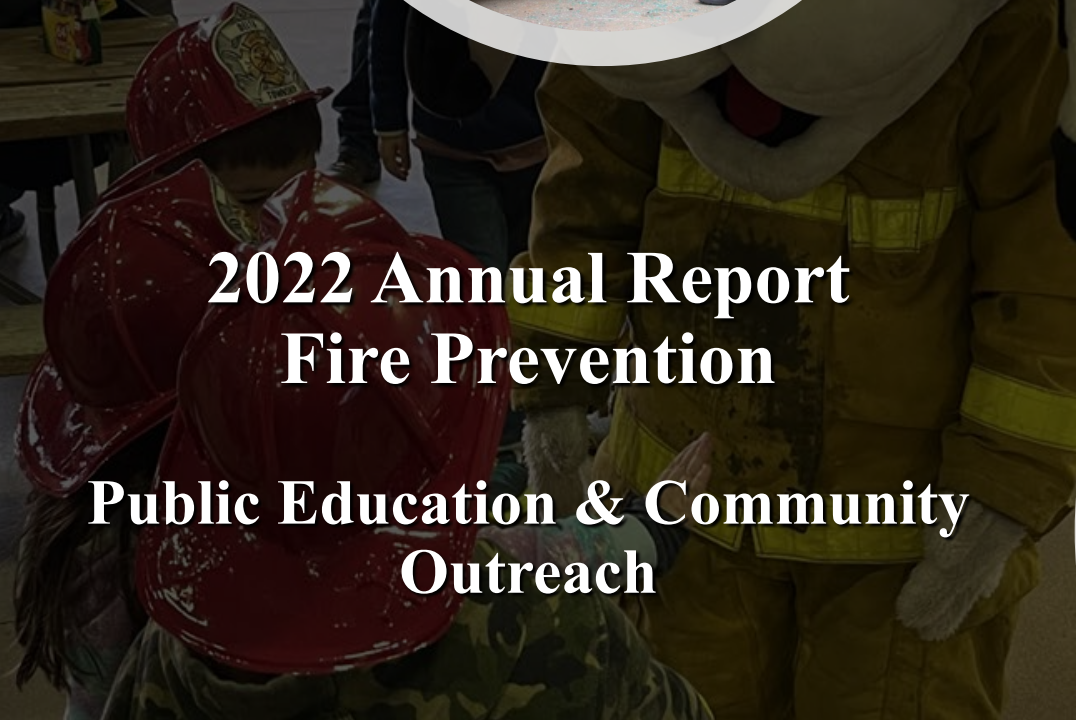

2022 Annual Report Fire Prevention

Public Education & Community Outreach



Total Fire Loss

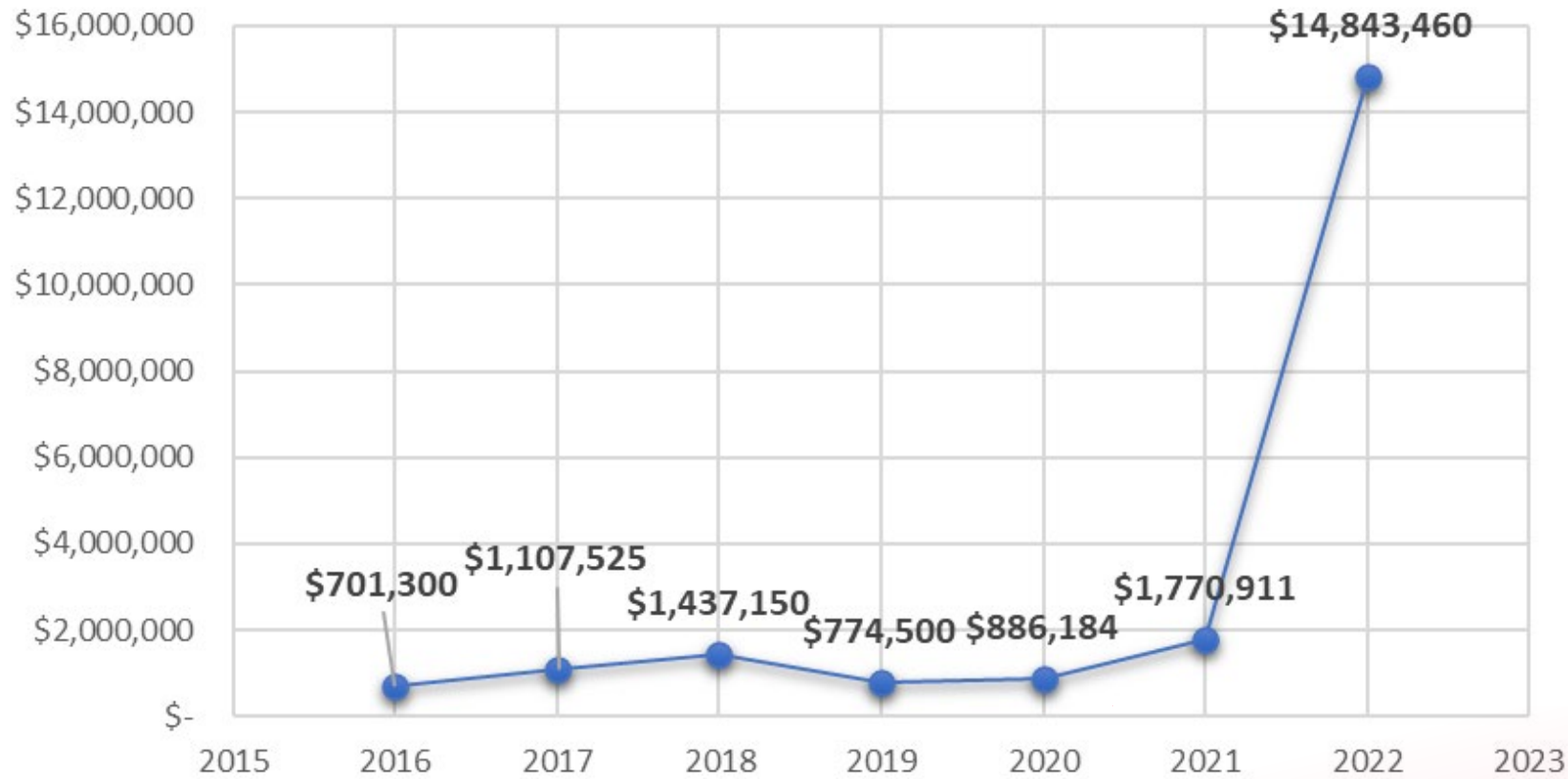

Fire Loss 7-Year Comparison

2022 Annual Report

Youth Fire Prevention & Intervention



Annual Inspections: 104
Plan Reviews: 64
Site Plan Reviews: 10
Fire Investigations: 25

- Ivan Woods Apts.
- Elmwood Park Apts.
- Covington Woods Apts.
- GM Parts Plant
- Munters
- Gilden Woods
- KinderCare
- Morgan's Early Learning Center
- Happy Elephant Child Care
- Just Imagine Preschool
- St. Gerard's Catholic School
- Our Savior Lutheran School
- Greater Lansing Adventist School
- New Covenant Christian School
- Eaton Co Youth Services
- Eaton Co Prosecutor's Office
- Barry County
- Eaton Co. KIDS Network
- Waverly & Grand Ledge Schools
- University of Michigan Hospital Burn Center
- Community Risk Reduction Task Force
- MFIT (Metro Fire Investigation Team)

2022 Annual Report Fire Prevention Division

- Burning Permits
 - Delta Township (1,574)
 - Looking Glass Regional Fire Authority (1,293)
- **2,867 Burning Permits Issued in 2022**





5,120 Training Hours

Training Division

- Behavioral Wellness
- Suicide Prevention/Awareness
- Cancer Prevention
- EMS
- Fire Tactics-Blue Card
- Fire Prevention
- Fire Officer I, II, III
- OSHA/MIOSHA
- ISO
- NFPA
- Live Fire Certification Training
- Active Assailant
- Hazardous Materials
- Confined Space Rescue
- Technical Rescue
- Collapse Rescue
- Ice Rescue
- Swift Water Rescue
- Emergency Management
- Driver Certification
- Human Resources Topics
- Incident Command System
- Traffic Incident Management
- Fire Instructor I, II



Emergency Management

- *Prevention*
- *Preparedness*
- *Response*
- *Recovery*
- *Mitigation*

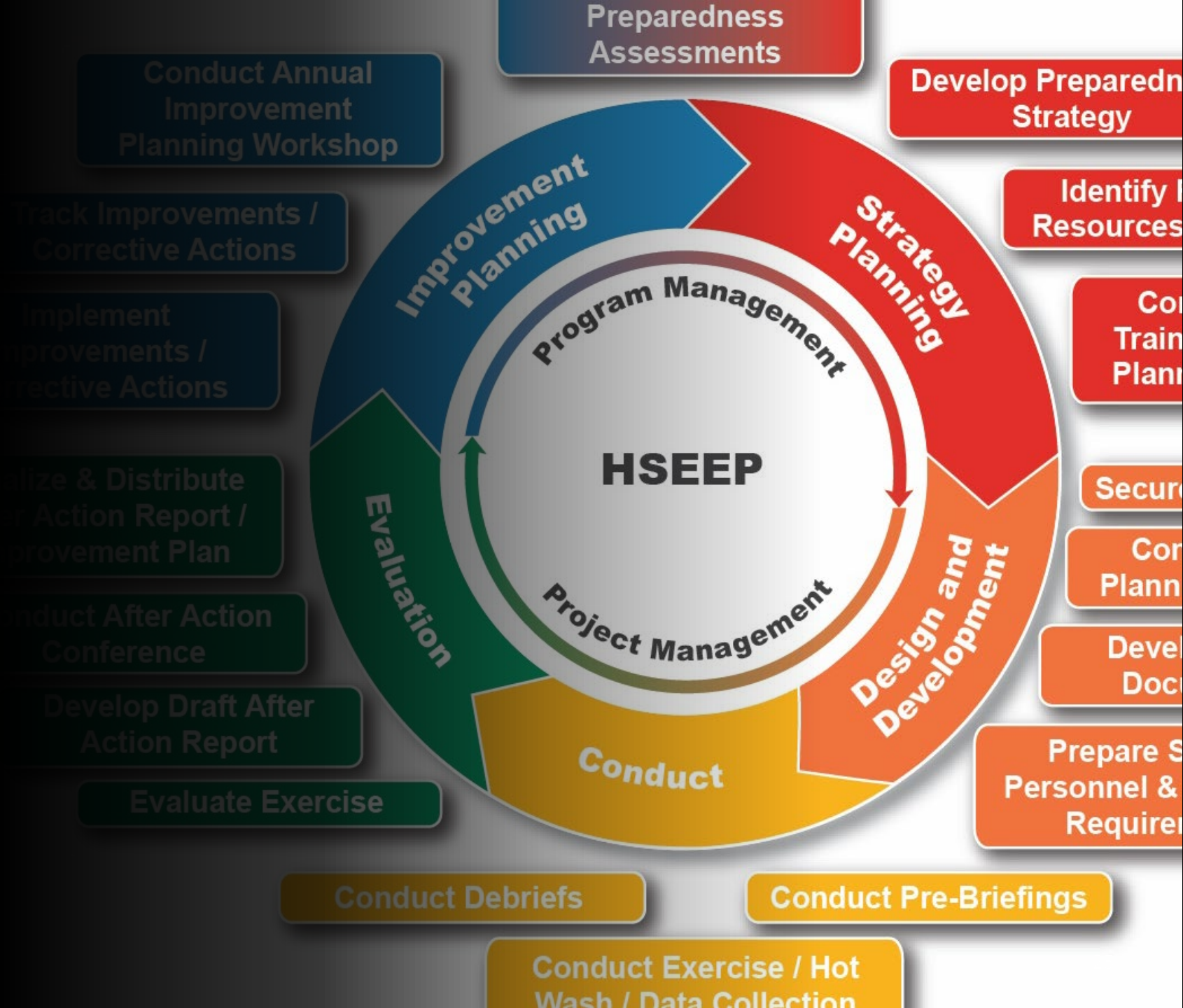

DELTA TOWNSHIP Emergency Management



STRONG PEOPLE STAND UP
for themselves

STRONGER PEOPLE
STAND UP FOR OTHERS

ok2say.com
652729 (OK2SAY)
iPhone & Android
855-565-2729
ok2say@mi.gov

OK 2 SAY
Stop the Silence. Help End the Violence.

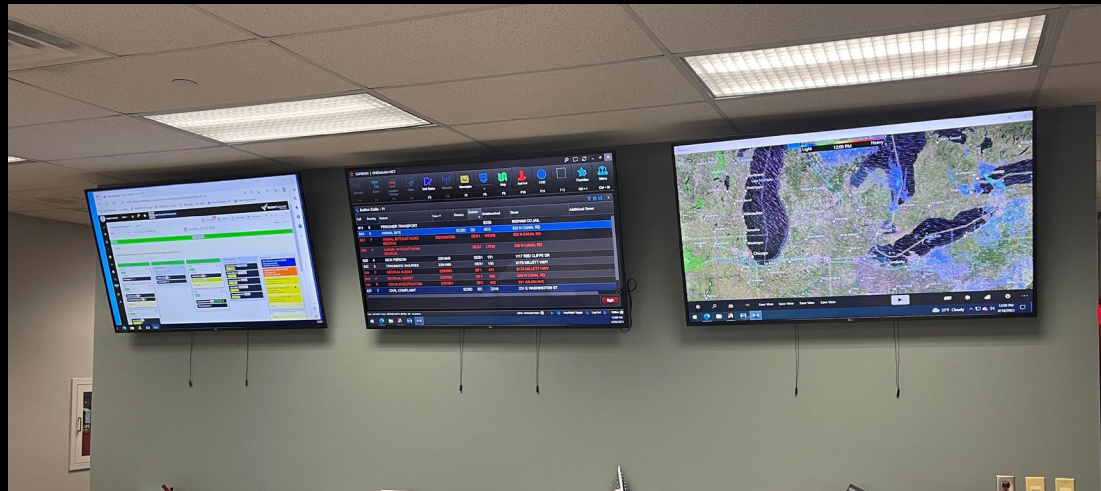

Small Chance of a Severe Thunderstorm South
Wednesday, March 23, 2022

When
Highest Potential
3 pm to 10 pm

Strongest Storms May Produce

- Isolated Large Hail
- Locally Damaging Wind Gusts
- Locally Heavy Rain

National Weather Service Grand Rapids, MI

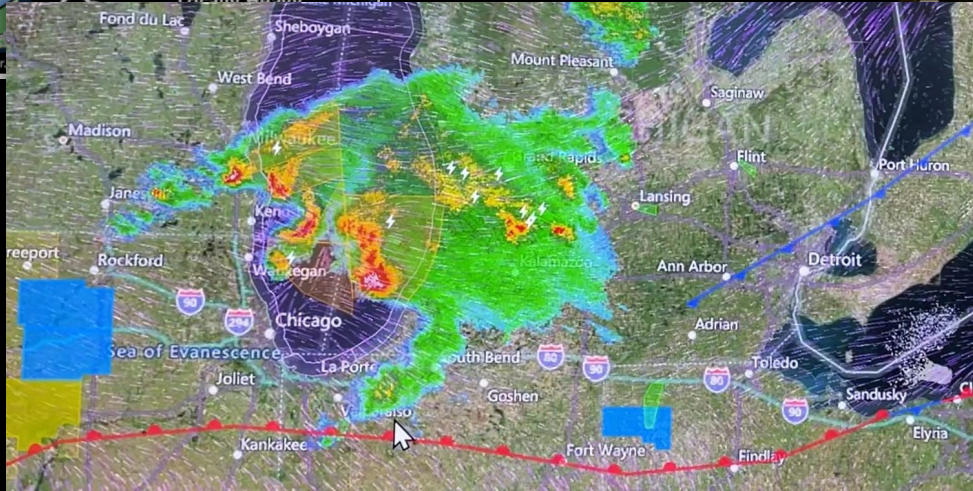



Department Successes

2022 Annual Report Department

Successes

- ***Ordered 2 New Ambulances***
 - ***Ordered 100' Aerial Platform***
 - ***Ordered New Heavy-Duty Pumper***
 - ***ISO 5-Year Department Evaluation***
 - ***Vulnerability Assessment Completed***
 - ***Hired Firefighter EMT's – attending paramedic school***
-



2022 Annual Report Department Successes

*2022 Delta Township
Fire Department
Firefighter of the Year*

*Firefighter Amanda
West*



Future Goals

(Listed for 2022)

Expanding/Changing
Recruiting Model

Completion of Lexipol Policy
& Procedures Program

Regional Training
Center/Live Burn

Fire Training Officer (FTO)
Program Curriculum

Departmental Challenges

ISO

ISO 5-Year Evaluation – Performance Improvement Plan



Staffing For Our Current Needs & The Future
Retirements in 2024: 5 starting in May



New CAD System Project

In Memory of Aaron Andrew Gorden



- Hired as a Firefighter
Paramedic 1/6/2000
- Promoted to Engineer
7/16/2020

March 23, 1973 – May 30, 2022



Questions?

DELTA TOWNSHIP
Emergency
Management

A teal-colored outline map of the state of Michigan is positioned to the right of the text. A small yellow star is located in the lower-right portion of the map, representing the location of Delta Township.